



WHAT'S NEW IN MASTERCAM 2018

February 2017

POWERED BY MASTERCAM'S
DYNAMIC MOTION™ TECHNOLOGY



Mastercam®

Be Dynamic.

WHAT'S NEW IN MASTERCAM 2018

February 2017

© 2017 CNC Software, Inc. – All rights reserved.

Software: Mastercam 2018

Terms of Use

Use of this document is subject to the Mastercam End User License Agreement. The Mastercam End User License Agreement can be found at:

<http://www.mastercam.com/companyinfo/legal/LicenseAgreement.aspx>

Be sure you have the latest information!

Information might have changed or been added since this document was published. The latest version of the document is installed with Mastercam or can be obtained from your local Reseller. A ReadMe file (ReadMe.PDF) – installed with each release – includes the latest information about Mastercam features and enhancements.

TABLE OF CONTENTS

Introduction	11
Product Changes	11
Mastercam Resources	11
Contact Us	12
General Enhancements	13
Analyze Enhancements	13
Analyze Toolpath	13
Analyze Distance Along Curve	15
Lathe coordinates	16
Propagate arc radius	16
Statistics	16
Bounding Box Face Points	17
Command Finder	18
Create New Viewsheets	19
Create Plane Dynamically	19
Delete Duplicates	20
Dimmed and No Hidden Wireframe	20

Endpoints	21
General Toolpath Enhancements	22
Improved access to chaining tolerance	22
Probe operation associativity	23
Stock display	23
Guided Chaining	24
Importing/Exporting Enhancements	26
CATIA Translator now imports hidden entities	26
Keep names when exporting solid bodies	26
Naming levels and solid bodies from imported solid assemblies ...	26
New options available when importing STL files	27
Levels Manager	29
Ignore blanked entities in count	29
Import via drag and drop	29
Mastercam Simulator	29
Create bookmarks	30
Create presentation	30
Machine Simulation	31
My Mastercam	34
Named Groups Quick Mask	34

Nesting Enhancements	36
Create labels	36
New location for temporary files	36
User-defined maximum priority	37
New Plane/Edit Plane Function Panel	37
Planes Manager	40
Import via drag and drop	40
Isometric reverse and trimetric planes	42
Saving Files Workflow	43
Mastercam control definition files	44
Mastercam machine definition files	44
Mastercam part files	45
Selection Enhancements	46
Enhanced Solid and Surface Selection	46
Selection masking for sheet bodies	48
Similar face selection	49
Window selection support	49
Setup Sheet Enhancements	49
Additional image support	49
Viewsheets and levels support	50

Social Media Links	50
System Configuration	50
Default file open type	50
Selection window color	52
Update to Parasolids 29.1	52
User Interface Changes	53
Work Offsets	55
XML Post Text	56
Design Enhancements	59
Angle Sweep	59
Seam Control	60
Drafting Enhancements	61
Align Note	61
Cross Hatch	62
Leader	63
Smart Dimension	64
Model Prep Enhancements	65
Hole Axis	65
Multiple Undo/Redo	66
Solid Enhancements	66

Solid Sweep	66
Solids Manager	70
Keep solid feature color	71
Solid face masking	71
Transform Enhancements	71
Control start position	71
Scale conversion	72
Wireframe Enhancements	72
Curve creation	72
Create Letters	74
Edit Spline	75
Helix and Spiral	76
Line Endpoint	77
Modify at Intersection	78
Tool Enhancements	79
Improved Inch and Metric Support	79
New Tool Importers	79
Importing with CoroPlus	80
Importing with Machining Cloud	82
Mill Enhancements	83

General Enhancements	83
Drill point sorting	83
Override arc feed rate	84
2D Enhancements	85
Contour	85
Depth cut direction	88
Depth cut order	89
Finish passes	89
Linking associativity	91
Plunge entry support	92
Spring passes	93
Stock awareness	94
Undercut support	94
Taper support	95
3D Enhancements	95
Disable undercut tool support	95
Follow containment	96
High speed workflow	96
Smoothing	98
Multiaxis Enhancements	99

Collision Control page	99
Common direction	100
Dropping	101
Line distance from curve	102
Maintain tilt	102
Multiaxis Link Safety Zone	103
Surface edge tolerance	104
Lathe Enhancements	106
Chip Break	106
Groove Enhancements	108
Cut direction options	108
Starting location	110
Prevent Up Cutting	111
Rough Enhancements	113
Section turning	113
Semi-finish speed and feed	115
Stock Model Support	115
Tool Inspection	115
Mill-Turn Enhancements	116
Center Support	116

New Center Point toolpath	117
New Tailstock Operations	119
General Enhancements	120
Job Setup Enhancements	121
Enable destination spindle	121
Manually define stock	122
STL models	122
Stock Type - Part Handling	123
Tool Locators for B-axis Heads	124

INTRODUCTION

Welcome to Mastercam 2018! Mastercam 2018 features new functionality focused on delivering speed and efficiency to your machining jobs.

Product Changes

Two changes have been made to the Mill Entry product. The **2D chamfer Contour type** is now available for a 2D Contour toolpath. The Rough **Cutting methods, Constant Overlap Spiral** and **Parallel Spiral** are also now available for a 2D Pocket toolpath.

Mastercam Resources

Enhance your Mastercam experience by using the following resources:

- *Mastercam Documentation*—Mastercam installs a number of helpful documents for your version of software in the `\Documentation` folder of your Mastercam 2018 installation.
- *Mastercam Help*—Access Mastercam Help by selecting **Help, Contents** from Mastercam's File tab or by pressing **[Alt+H]** on your keyboard.
- *Mastercam Reseller*—Your local Mastercam Reseller can help with most questions about Mastercam.
- *Technical Support*—Our Technical Support department (860-875-5006 or support@mastercam.com) is open Monday through Friday from 8:00 a.m. to 5:30 p.m. USA Eastern Standard Time.

- *Mastercam Tutorials*—We offer a series of tutorials to help registered users become familiar with basic Mastercam features and functions. Visit our website, or select **Help, Tutorials** from Mastercam's File tab to see the latest publications.
- *Mastercam University*—Mastercam University, an affordable online learning platform, gives you 24/7 access to Mastercam training materials. Take advantage of more than 180 videos to master skills at your own pace and help prepare for Mastercam Certification. For more information on Mastercam University, please contact your Authorized Mastercam Reseller, visit www.mastercamu.com, or email training@mastercam.com.
- *Online Communities*—You can find a wealth of information at www.mastercam.com. For tech tips and the latest Mastercam news, follow us on Facebook (www.facebook.com/mastercam), Twitter (www.twitter.com/mastercam), or Google+ (plus.google.com/+mastercam). Visit our YouTube channel to see Mastercam in action (www.youtube.com/user/MastercamCadCam)! Registered users can search for information or ask questions on the Mastercam Web forum, forum.mastercam.com, or use the knowledgebase at kb.mastercam.com.

Contact Us

For questions about this or other Mastercam documentation, contact the Technical Documentation department by email at techdocs@mastercam.com.

GENERAL ENHANCEMENTS

Listed below are general enhancements made to Mastercam 2018. This includes improvements to selection, general toolpath enhancements, and other functions not specific to one product line.

Analyze Enhancements

Listed below are enhancements made to the **Analyze** functions, located on the Home tab.

Analyze Toolpath

5-axis vector information

Analyze Toolpath now includes XYZ location data corresponding to the mouse location at the start (green) or end (red) of the toolpath segment. This information is in addition to the feed and speed data that is shown between the start and end of the segment.

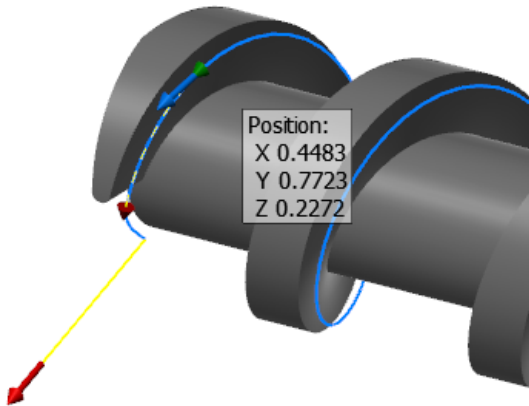

Display options

You can choose to display or hide the tool and holder during Analyze Toolpath. Use the **Opacity** slider to control their translucency.

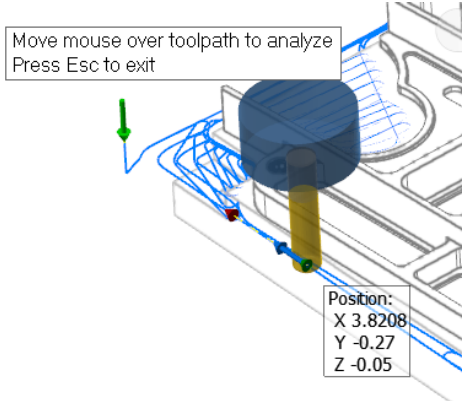
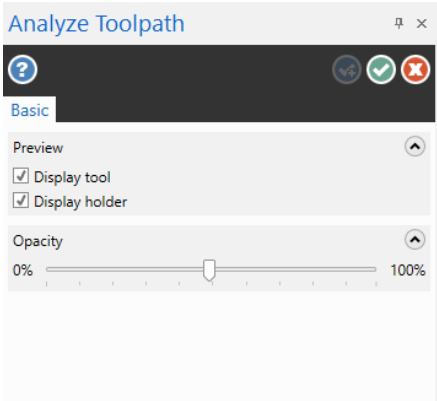

Analyze Distance Along Curve

A new Analyze function is now available on the **Home** tab, under **Analyze Distance**. Analyze Distance Along Curve allows you to find the distance along a line, arc, or spline edge without having to trim or break it first.



Analyze Distance Along Curve

Units
Millimeters

Precision
N.1234

Distance
527.2717

Start Angle
0.0

End Angle
0.0

Sweep Angle 1
360.0

Sweep Angle 2
0.0

✓ ?

Unlike Analyze Distance, Analyze Distance Along Curve does not measure a linear distance, but rather the length along the curve between two user-defined points.

This function reports the following position coordinates as they relate to the Cplane origin:

- Distance
- Start angle

- End angle
- Sweep angles

Lathe coordinates

Analyze Position now displays when a DZ construction plane is now active.

Propagate arc radius

When using **Analyze Entity** on an arc or radius, you can now apply a diameter to all selected arcs by selecting **Propagate arc radius** on the dialog box.

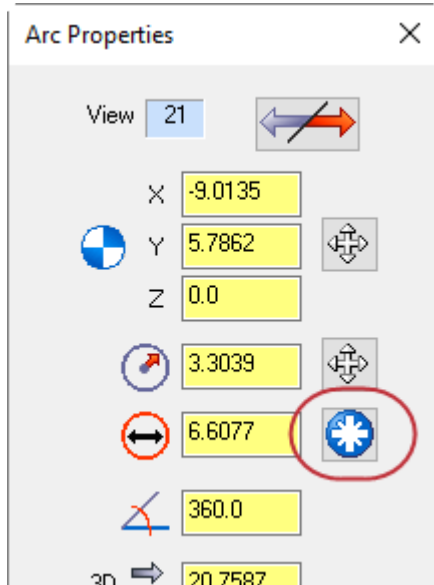

Statistics

Statistics now reports the number of sheet solids in the current part file.

Bounding Box Face Points

In Mastercam 2017, Face center points were introduced and were tied to Center points. Now, Face center points and Center points are independent of each other.

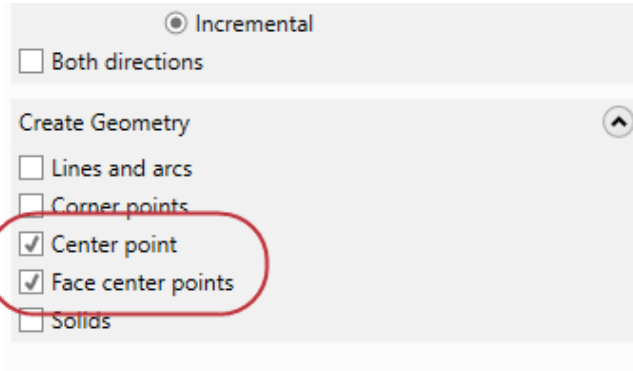

You can use the **Center point** option to create a single point in the middle of the Bounding Box and/or use the **Face center points** option to create points at the center of each face, or use both at the same time.

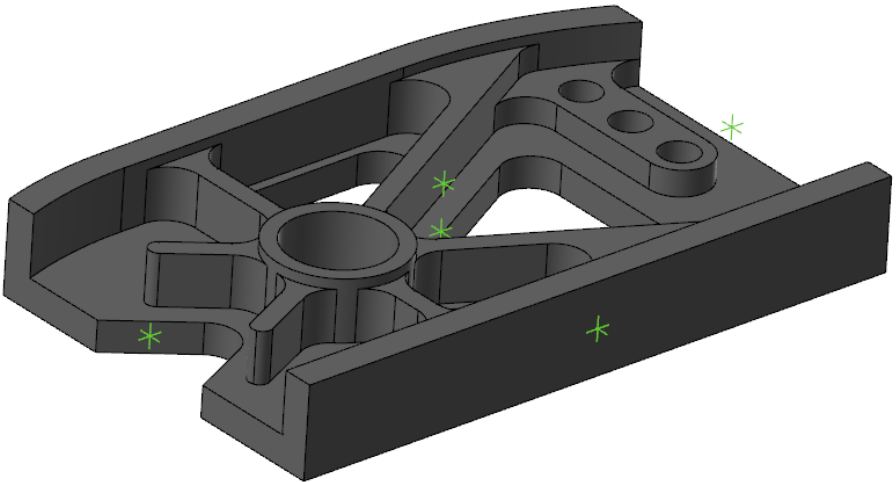

Command Finder

The Command Finder utility, which searches for and opens Mastercam functions, has been added to the **Home** tab.

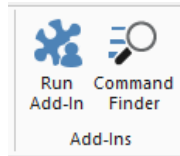

The Command Finder opens as a floating window that can be repositioned and remains on-screen until you close it.

Enter a word in the Command Finder and Mastercam returns a list of possible matches that include a short description of the function.

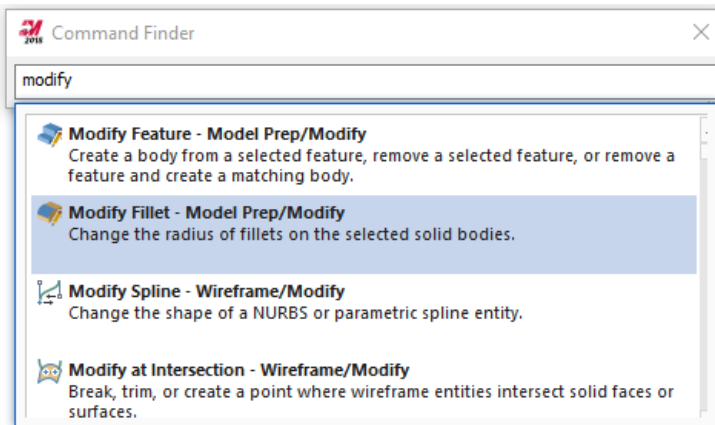

Double-click a search result to open that function.

You can also add the Command Finder to the Quick Access Toolbar (QAT), or assign it a keyboard shortcut.

Create New Viewsheets

In Mastercam 2017, to create a new viewsheet, you had to right-click on a viewsheet and select **New Viewsheet**.

In Mastercam 2018, you can also create new viewsheets by clicking **New** to the right of the viewsheet tabs. The new tab is highlighted, so that you can input the name immediately after creating the viewsheet.

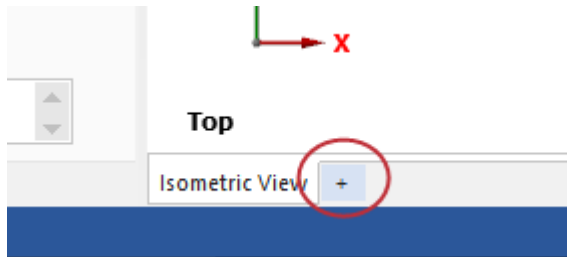

Create Plane Dynamically

A new option has been added to Trim by Plane and to the Plane Selection dialog box, that launches the New Plane function panel.

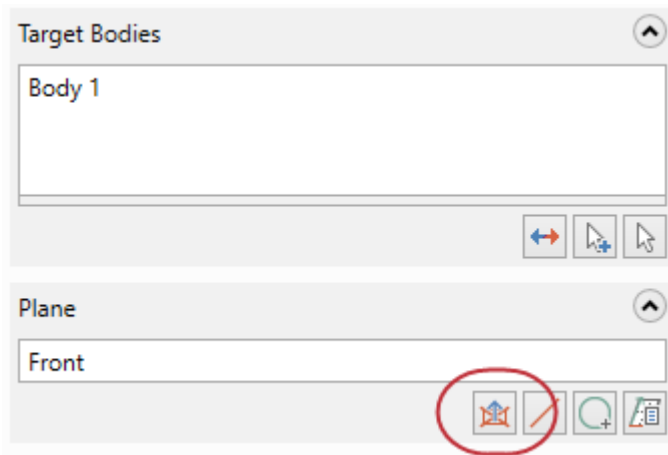

This allows you to create a dynamic plane without exiting the current function. By default, the new plane is added to the Planes Manager.

Delete Duplicates

Delete Duplicates now identifies duplicate arcs, even when they have different start and end angles.

Dimmed and No Hidden Wireframe

STL entities can now be displayed in **Dimmed** and **No Hidden** Wireframe view modes as shown in the following examples.

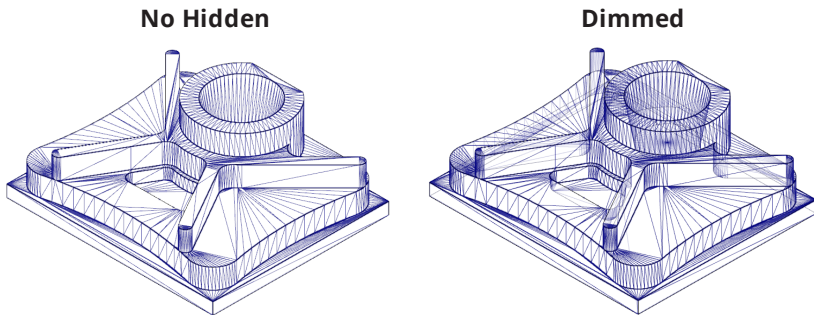

Endpoints

Endpoint display has been enhanced, now displaying as solid white circles with a black outline to provide contrast with different geometry and background colors.

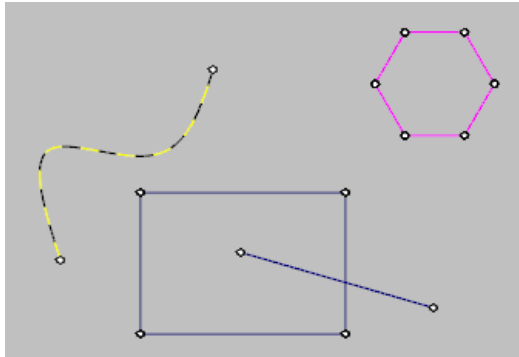

You can toggle **Endpoints** on the **Home** tab to display or hide geometry endpoints. Your setting will persist across multiple sessions of Mastercam. The size of the endpoints is not configurable, and they do not scale when the screen is re-sized.

General Toolpath Enhancements

Listed below are enhancements made to toolpaths that are not specific to one product line.

Improved access to chaining tolerance

Chaining tolerance is now stored with the chains in the Chain Manager. The value in the Chain Manager only affects the selected toolpath and is applied to all subsequent regenerations of the operation.

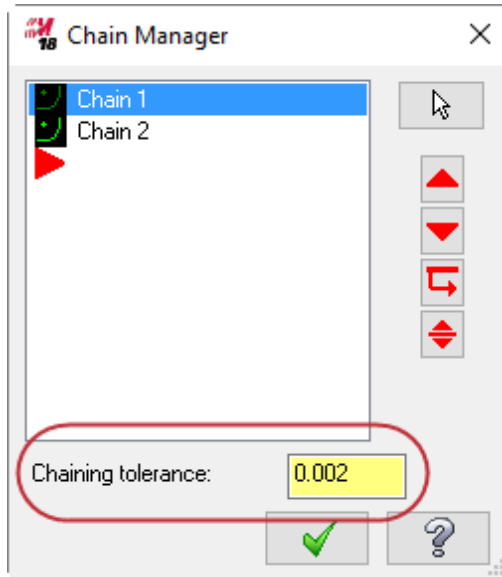

Other toolpaths will continue to default to the chaining tolerance set in the Tolerances page of System Configuration.

Probe operation associativity

Probe operations are now associated to their selected geometry. As with other operations in Mastercam, when you move or modify the geometry used in the Probe operation and regenerate, the operation will update with the new geometry. You no longer need to recreate the Probe operation.

Stock display

The **Stock Display** and **Stock Shading** options, that were previously available on the **View** tab in Mastercam 2017, are now located on the specific machine type tab and have been expanded.

In the case of Mill, Router, and Wire machine types, Stock Display works as it did in previous versions. For Lathe and Mill-Turn machines, you can now control which stock components are displayed in the graphics window.

For Lathe machines, the available components must be defined in the Stock Setup page of the Machine Group Properties dialog box. For Mill-Turn machines, the available components depend on your Job Setup and your current machine.

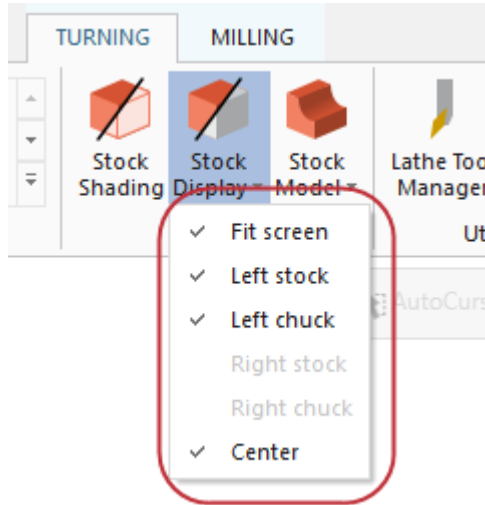

If a component is not defined or available for your current machine setup, the option is disabled from the **Stock Display** drop-down.

Guided Chaining

You can now guide and select the next entity in a chain when a branch point has been reached. Guided chaining is available in **3D Wireframe** and **Linked Edges** mode for solids.

To use guided chaining, click a 3D wireframe or linked edge to begin chaining. When a branch point is reached, a red arrow displays pointing in the direction of the default next direction/entity. One or more blue arrows display pointing in the direction of any alternate branches as shown in the following example.

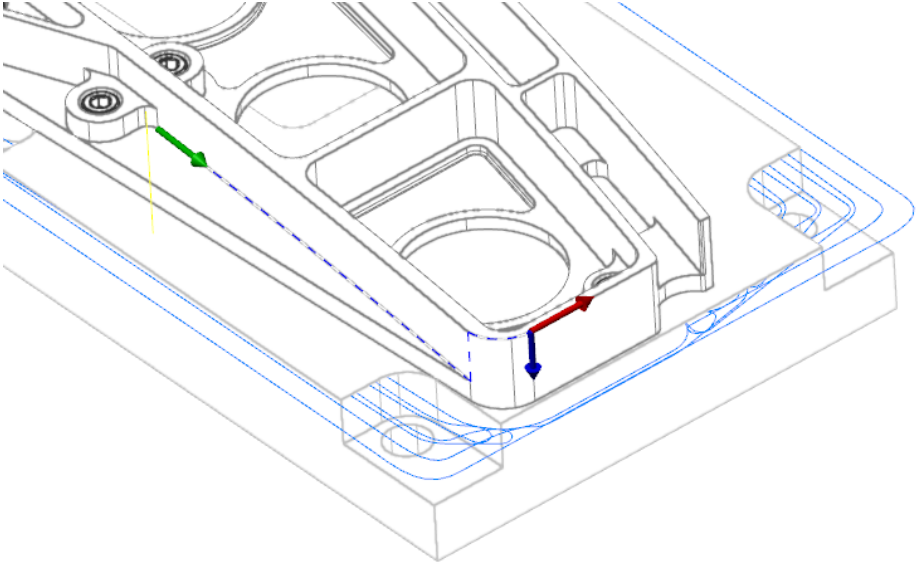

Two new controls are now available on the Chaining dialog box:



Use **Next** to continue in the direction of the red arrow.



Use **Adjust** to select a different direction/entity.

Alternately, you can click on the red or blue arrow to advance the chain in that direction.

Importing/Exporting Enhancements

Listed below are enhancements made to importing and exporting other supported file types, such as CATIA and SOLIDWORKS files.

CATIA Translator now imports hidden entities

When importing CATIA files, Mastercam will also import any hidden entities and place them on a level.

Keep names when exporting solid bodies

When exporting solids to other CAD formats, Mastercam will now export the solid name data with the bodies.

Naming levels and solid bodies from imported solid assemblies

When importing solid assemblies, Mastercam's file importers use a new protocol to populate both the Solids and Levels Manager. Mastercam processes the solid depending on what type of information is available from the incoming file format. If there is no level or body name data in the imported file, the body and the level name are the file name.

Levels Manager

- Level names from the imported file or assembly are preserved in the Mastercam part file.
- Even when importing from formats with no level data, Mastercam places the imported solid bodies on separate levels.
- The level name is based on the solid body name, when possible.
- When you open a Solid Edge, SOLIDWORKS, or Parasolid file that contains multiple solid bodies, each body is placed on its own level. When the information is present in the original file, Mastercam

assigns the solid body name to each level. To change this behavior, deselect **Assign Level names to match Solid names** on the Converters page of System Configuration.

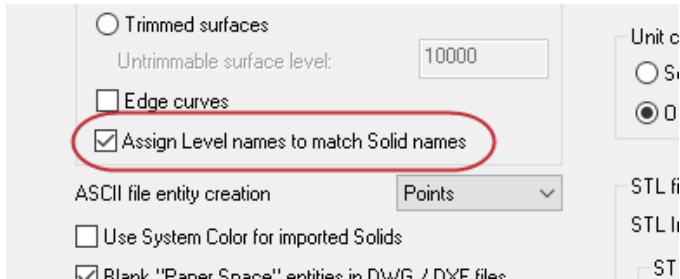

Solids Manager

- Mastercam names and appends a number to each imported solid body in a STEP file that contains multiple solid bodies (Filename+n).
- Mastercam organizes the various solid bodies of an assembly in the Solids Manager.
- Whenever possible, Mastercam names each imported solid body.
 - Names for imported solid bodies are independent of the imported level names.
 - Multiple bodies with the same name will have numbers appended.
- Bodies in separate part files in assemblies will include the name of the assembly in the Solids Manager.

New options available when importing STL files

There are new options available on the STL Read Parameters dialog box. To access this dialog box, choose an STL file, and select **Options** in the Open dialog box.

- Create open edge geometry
- Create sharp corner edge geometry
- Offset the triangle data inward or outward
- Save the stitched and/or offset data to a new STL file

Levels Manager

Listed below are enhancements made to the Levels Manager.

Ignore blanked entities in count

Select **Ignore blanked entities in count** from the **Display options** drop-down to not include blanked entities in the Entities column count. This option is off by default.

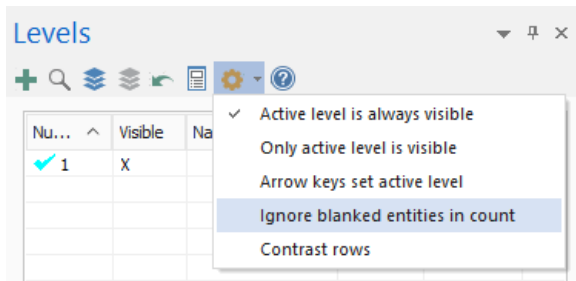

Previously, blanked entities were included in the entity count and caused confusion between the count and visible entities on a level.

Import via drag and drop

You can now drag and drop a supported file (for example, .csv) onto the Levels Manager to automatically import that file's levels.

Mastercam Simulator

Listed below are enhancements made to Mastercam Simulator, accessed through the Toolpaths Manager.

Create bookmarks

You can now create bookmarks in Mastercam Simulator that refer back to various points during Verify, Backplot, or Simulation.

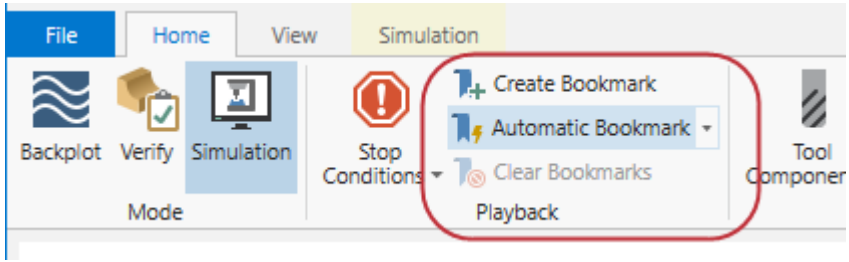

You can add a bookmark, clear a bookmark, or clear all bookmarks. Use **Automatic Bookmark** to insert bookmarks at certain locations, such as a tool change or operation change. The bookmarks are then displayed on the playback bar. Simply select any bookmark icon to display the part as it is at that moment. You can also use **Create Bookmark** on the playback bar to add a bookmark.

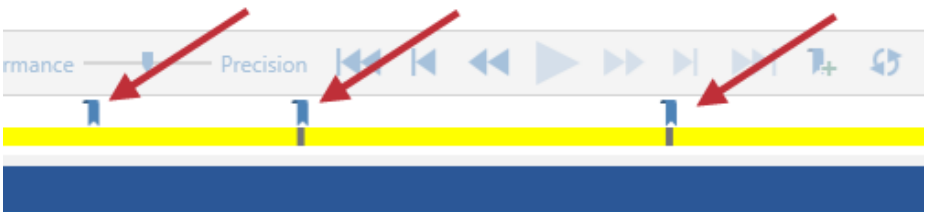

If you exit Mastercam Simulator or regenerate the toolpaths, the bookmarks are cleared automatically. They do not persist between sessions.

Create presentation

You can now create a presentation from Mastercam Simulator. Saving a presentation lets you preserve your settings and layout of your Mastercam

Simulator session and can be used to show a simulation on any computer, even if it does not have Mastercam.

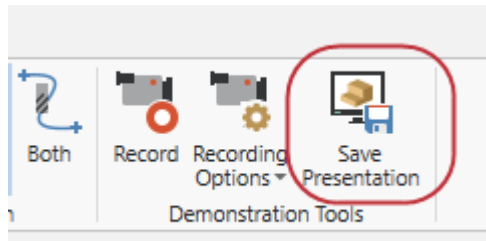

Select **Save Presentation** on the **Home** tab to create your presentation.

Machine Simulation

A light-weight version of Machine Simulation is now available within Mastercam Simulator. Select **Verify** from the Toolpaths Manager, and select **Simulation** on the **Home** tab to view the machine simulation.

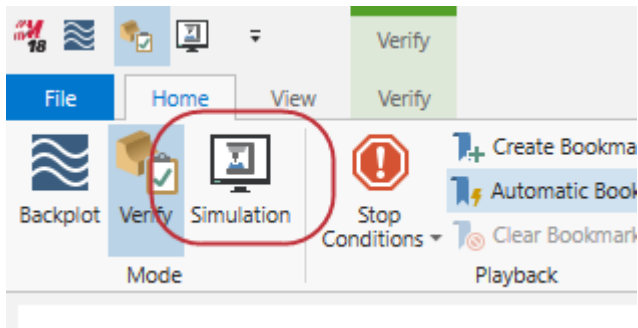

To set options for Machine Simulation inside Mastercam Simulator, select **Simulator Options** on the Toolpaths Manager to display the redesigned dialog box.

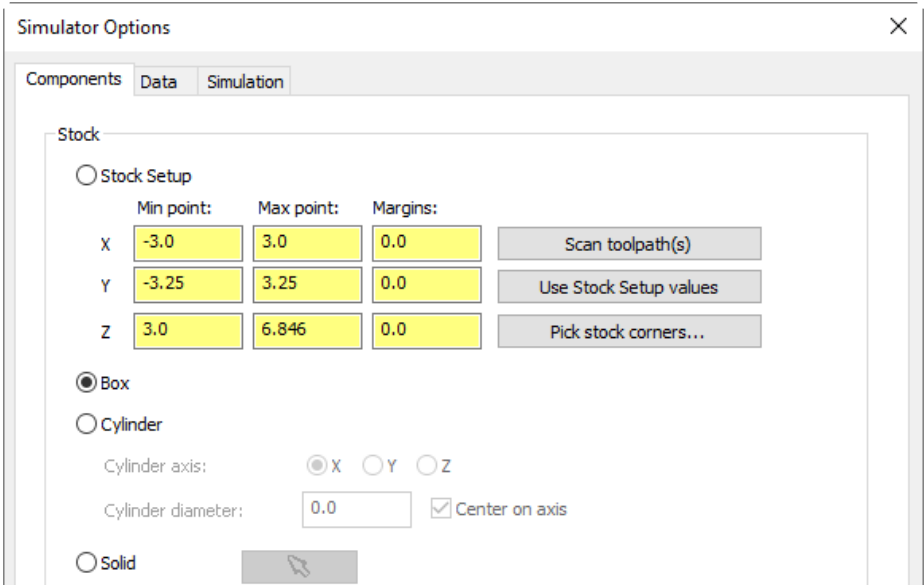

Use the **Components** tab to set up stock and fixtures. Use the **Data** tab to set tolerances. Use the **Simulation** tab to set the machine, position, and tolerance.

If you do not have a machine selected when entering Mastercam Simulator, Mastercam will default to a generic machine or a machine that was selected in the Machine Simulation dialog box for the standalone Machine Simulation.

Once inside of Simulation, you have access to the same options as you do in Verify mode. You can use clipping planes, save the stock as an STL, or use Collision Checking.

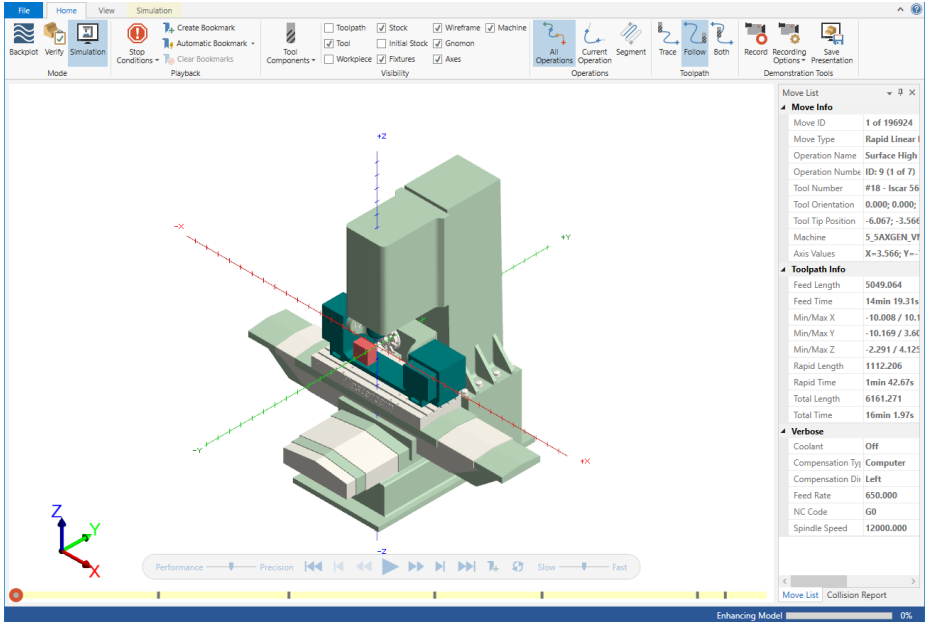

My Mastercam

You can now access your profile and other information by logging into My Mastercam, located in the top right corner of Mastercam 2018. Once logged in, you have access to Mastercam's social media outlets, your Reseller information, the Mastercam forum, and other helpful information.

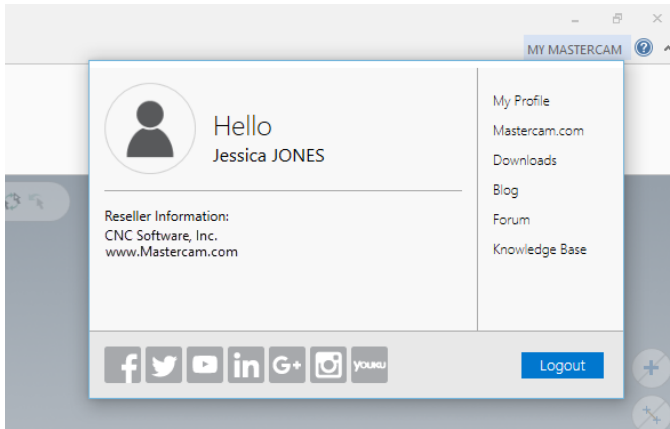

Named Groups Quick Mask

The **Named Groups** selection filter, which was previously available in Mastercam X9, has been added back to Quick Masks.

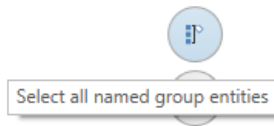

Selecting the **Select all named group entities** Quick Mask, opens the Groups Manager dialog box where you can select a group by name. Alternatively, you can select a member of the group, which will select the entire group.

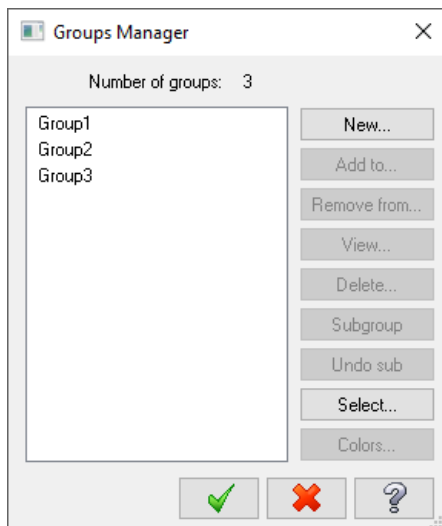

Nesting Enhancements

Create labels

Use **Place label on top of solid** to create labels on the top of the solid, instead of at Z zero. This new option is located on the Nesting Configuration dialog box.

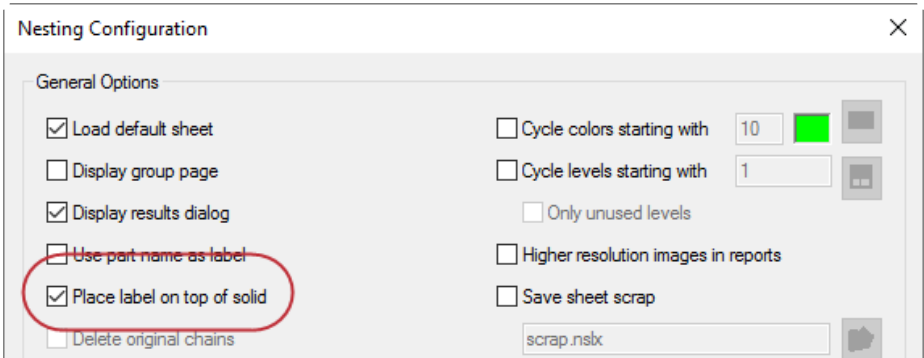

New location for temporary files

Temporary nesting files now go into Mastercam's default temp folder (. . . \mcam2018\common\TEMP) so that you can safely make them read-only if necessary.

User-defined maximum priority

You can now define the highest maximum priority value for parts and sheets in the Nesting Configuration dialog box.

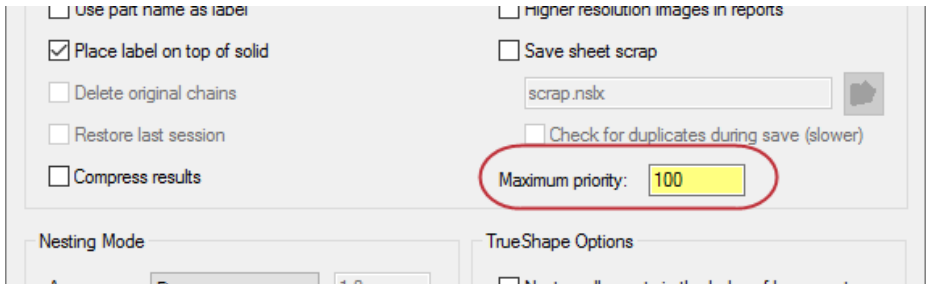

New Plane/Edit Plane Function Panel

Plane creation and editing has been merged into a new function panel that includes controls from previous Dynamic Plane and New Plane dialog boxes.

When creating a new plane by using the on-screen, dynamic gnomon, from the Planes Manager, using Trim to Plane, etc., the New Plane function panel opens. When editing an existing plane, the Edit Plane function panel opens. The function panels share the same controls, which are enabled or disabled as appropriate for the current mode.

These new function panels follow the same design guidelines as other functions in Mastercam, and provide a familiar work flow to users.

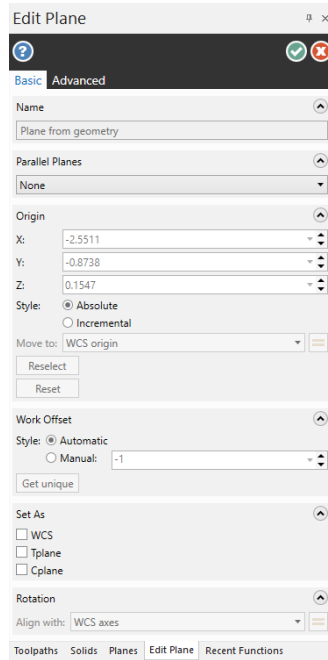
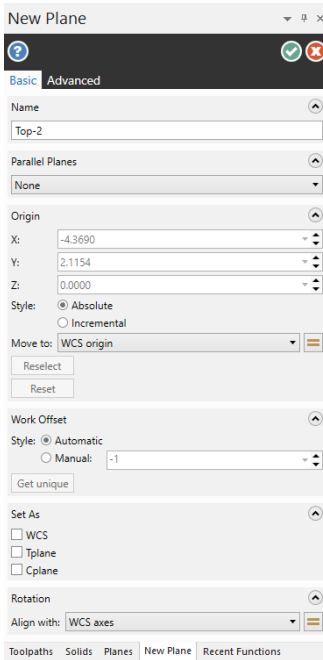

The **Basic** tab provides all the controls to create/edit a plane, and the **Advanced** tab includes planes attributes such as plane associativity and locking.

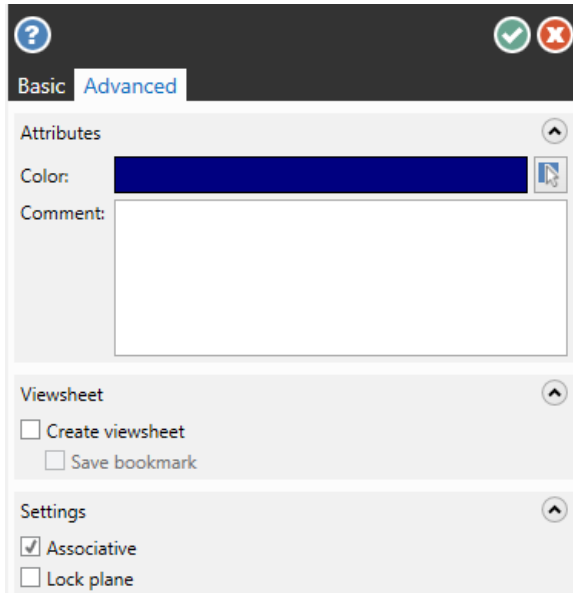

Planes Manager

Listed below are enhancements made to the Planes Manager.

Import via drag and drop

You can now drag and drop a supported file onto the Planes Manager to import the file's planes. The Plane Selection dialog box displays and lets you select which planes to import.

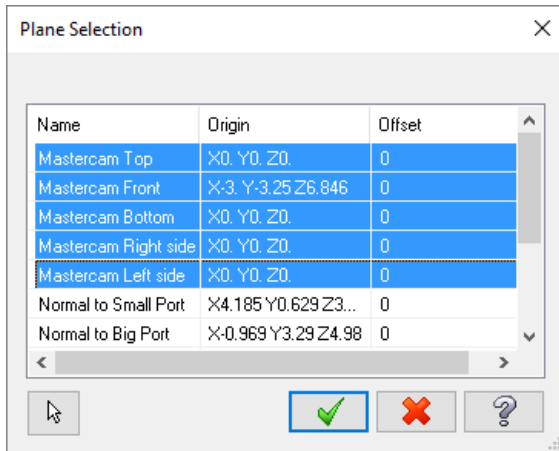

Select one or more planes to import and click **OK**. The planes are imported into the open Mastercam file.

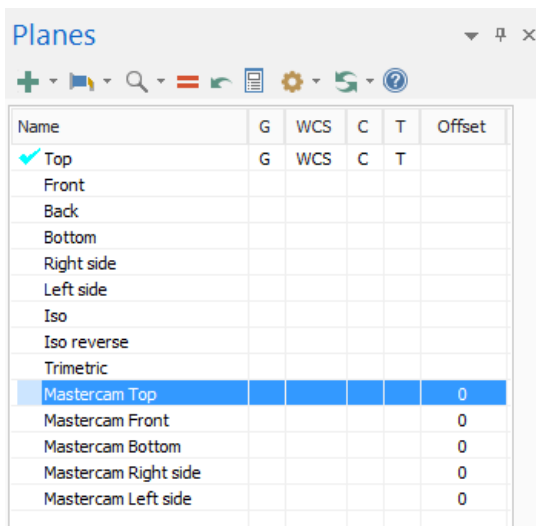

Isometric reverse and trimetric planes

Two new standard planes, Iso Reverse and Trimetric, have been added to the Planes Manager and to the Create Relative Planes dialog box.

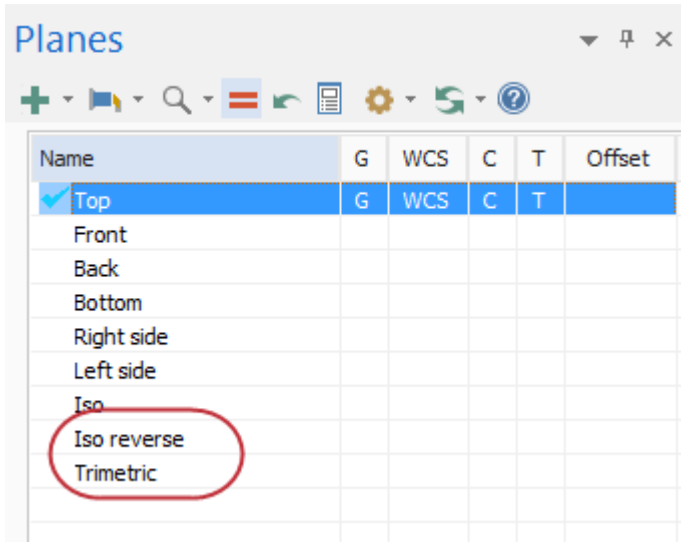

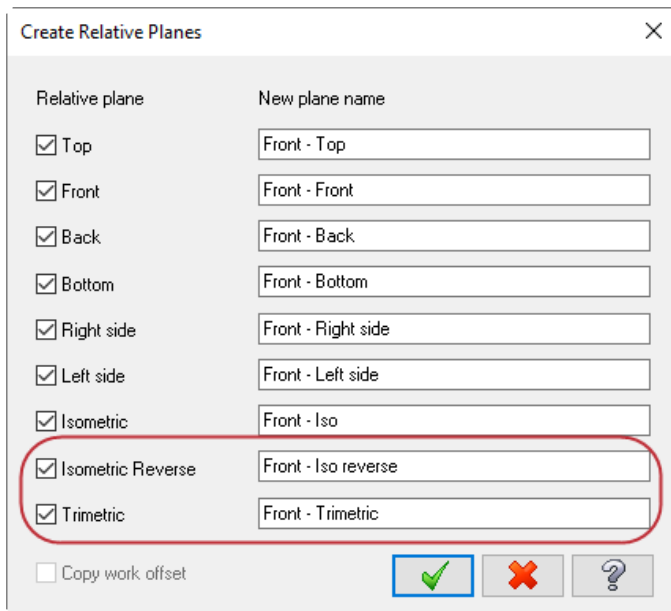

Saving Files Workflow

With the release of Mastercam 2017, file extensions no longer contain version numbers. To ensure that Mastercam does not overwrite your part, machine, and control definition files, the save file workflow has been changed.

Mastercam control definition files

When you open a Mastercam 2017 control definition file in 2018, Mastercam displays the following warning message:

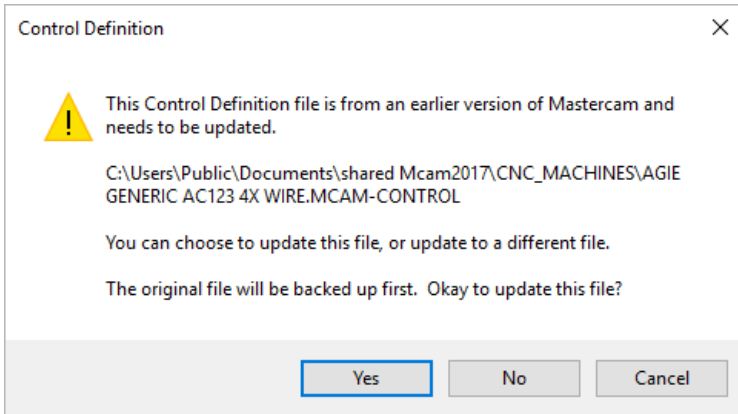

If you choose **Yes**, a backup of the original file is saved to the following location:

```
C:\Users\Public\Documents\shared Mcam2018\CNC_MACHINES\Older Versions\2017
```

If you choose **No**, the Save As dialog box displays, and you can rename the file using a unique name.

Mastercam machine definition files

When you open a Mastercam 2017 machine definition file and make a change, a backup of the original file is automatically saved to the following location:

```
C:\Users\Public\Documents\shared Mcam2018\CNC_MACHINES\Older Versions\2017
```

Any changes made to Mastercam X9 or older version machine definition files are saved with their original extension.

Mastercam part files

When you open a Mastercam X9 or older part file in Mastercam 2018, selecting **Save** opens the **Save As** dialog box, where you can save the file with the 2018 **.mcam** format.

When you open a Mastercam 2017 part file in 2018, you will see a warning banner in the interface that tells you the file is from a previous version of Mastercam.

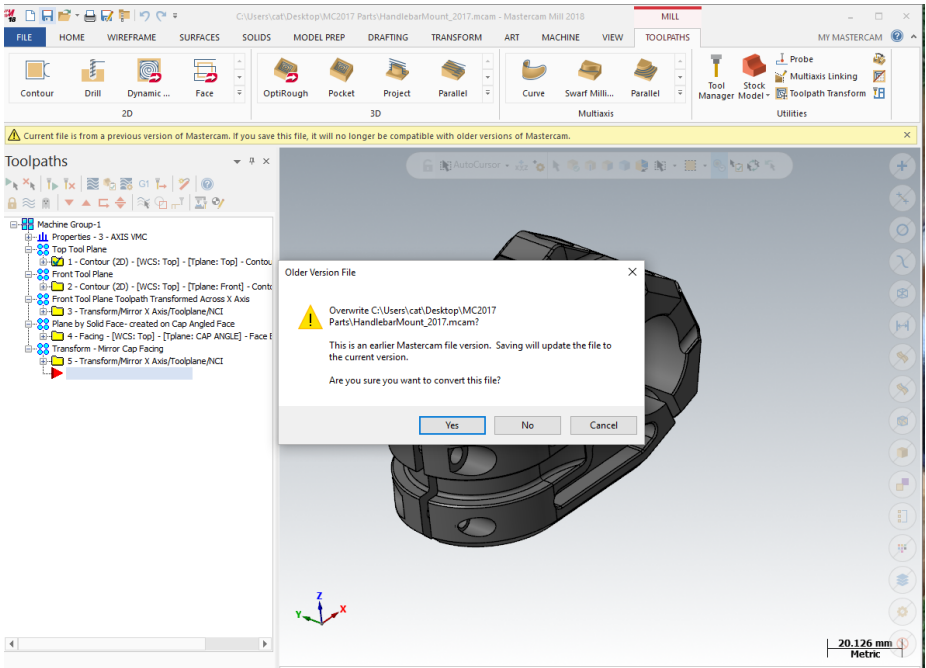

If you click **Save**, a warning will display. Choosing **Yes** saves the file as a Mastercam 2018 **.mcam** file, and choosing **No** opens the **Save As** dialog box.

Selection Enhancements

Enhanced Solid and Surface Selection

The selection of solids, surfaces, and STL entities has been improved. You can now select different types of entities without switching between Standard and Solid modes on the Selection Bar. These selection enhancements have been included in the following functions:

- Selecting machining drive and/or check geometry for 3D toolpaths
- Wireframe, Curve All Edges
- Wireframe, Curve Slice
- Wireframe, Curve at Intersection
- Wireframe, Curve Parting Line
- Transform, Project

When selecting geometry in one of these functions, the following buttons on the Selection Bar are disabled:

- Standard Selection
- Solid Selection
- Edge Selection

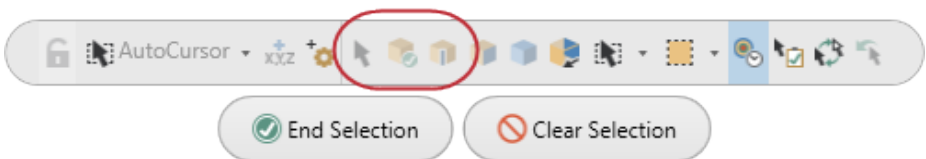

The **Body Selection** and **Face Selection** filters on the Selection Bar, as well as surface, solid, and polygonal mesh Quick Mask filters are supported during the selection process. If both the **Face** and **Body Selection** filters are

enabled, the cursor will alternate between face and body selection when moving over a solid.

Mastercam displays a prompt to guide you through selection techniques.

Hovering over a solid highlights the nearest face and displays the face selection cursor. Click to select a solid face or double-click to select a feature. If only the **Face Selection** filter is enabled, you can triple-click to select all faces of a solid body. Click an individual face of the solid to deselect it from the body.

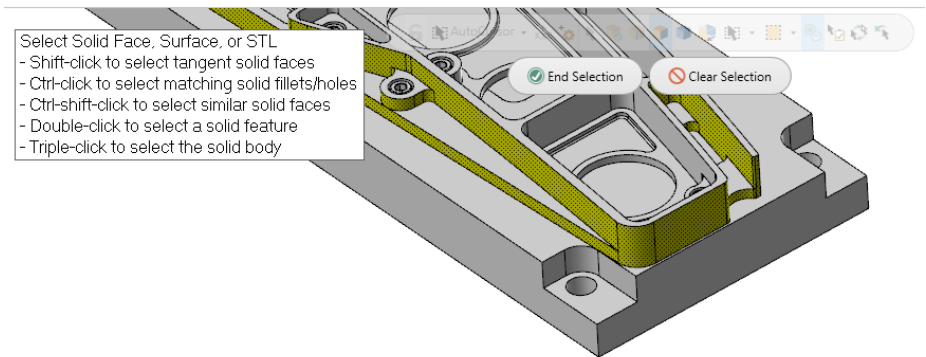

Use [**Shift+click**] to select a face and all tangent faces, or [**Ctrl+click**] to select similar solid faces. In addition, you can use [**Ctrl+Shift+click**] to select matching fillets or holes.

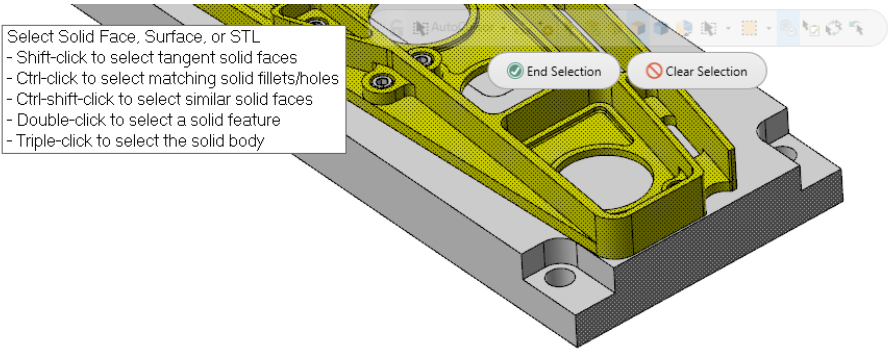

Pressing [**Esc**] or double-clicking in an open area of the graphics window accepts the selection.

Selection masking for sheet bodies

A new sheet solid selection capability has been added to the Select All and Select Only dialog boxes.

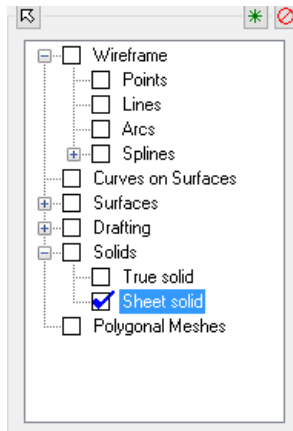

Similar face selection

You can now hold [**Ctrl+Shift**] to select and edit similarly sized faces in a single operation for the following Model Prep functions:

- Move
- Push/Pull
- Modify Features
- Change Face

Window selection support

Window selection is now available in Solid Selection mode to select solid bodies and/or faces.

It is also supported when using the Model Prep functions, **Push/Pull** and **Hole Axis**.

Setup Sheet Enhancements

Additional XML tags have been added to the database for Mastercam 2018.

Additional image support

Setup sheet can now generate these additional image types:

- JPG
- PNG
- GIF

Choose the desired format in the Setup Sheet dialog box.

Viewsheets and levels support

You can now include your viewsheet images in your report, or images based on levels in views. Select **Level** or **Viewsheet** on the Capture Images dialog box to include them into your report.

Social Media Links

You can now access Mastercam's social media outlets from the Mastercam.com login page and the Community page (accessed through the **File** tab). Click an icon to launch the website.

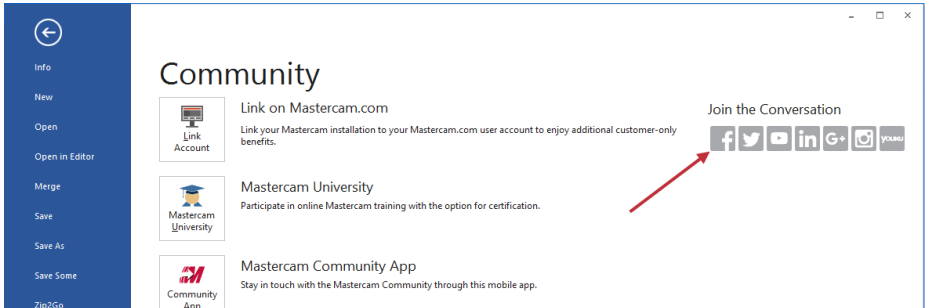

System Configuration

Listed below are enhancements made to System Configuration.

Default file open type

You can set a default file type to be used when opening a file.

On the Files page, choose a **Default file open type** from the drop-down menu as shown below. The setting persists from session to session.

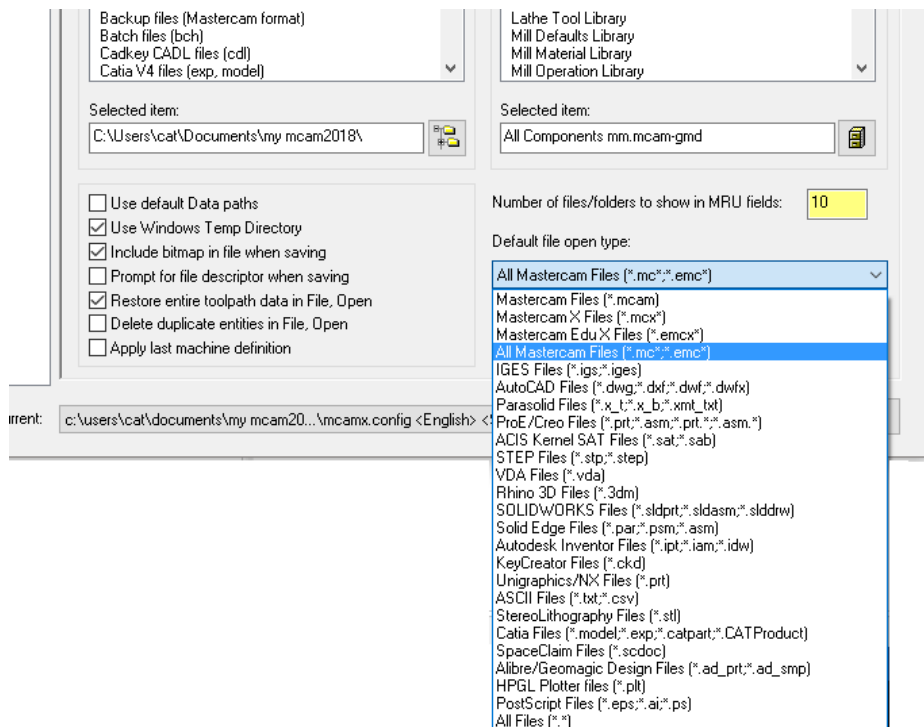

Selection window color

You can now set a default color for the selection window on the Colors page.

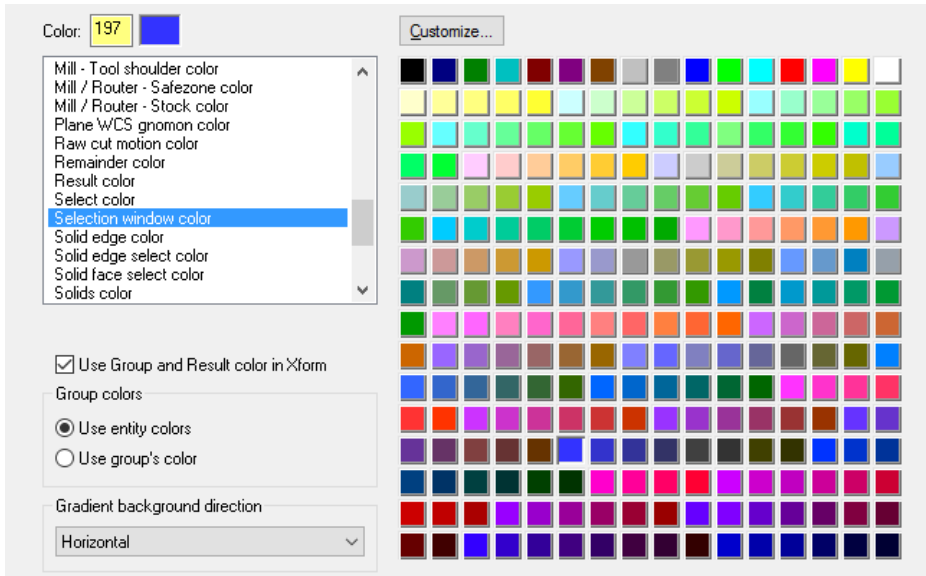

Update to Parasolids 29.1

Mastercam 2018 has been updated to use Parasolids 29.1, the latest Parasolids kernel. This upgrade allows Mastercam to do the following:

- Maintain compatibility with other CAD modelers
- Benefit from new features and capabilities, when possible
- Benefit from bug fixes within the kernel

User Interface Changes

The following functions have been converted to function panels for Mastercam 2018.

- 2 Surface Blend
- 3 Fillet Blend
- 3 Surface Blend
- Block
- Bolt Circle
- Cone
- Create Letters
- Cross Hatch
- Cylinder
- Ellipse
- Extrude Surface
- Fillet to Curves
- Fillet to Plane
- Fillet to Surfaces
- Fit
- Helix
- Leader
- Mirror
- Note
- Offset
- Offset Contour
- Polygon
- Project
- Rectangular Array
- Rectangular Shapes
- Roll
- Rotate
- Scale
- Silhouette Boundary
- Sphere
- Spiral
- Sketch
- Torus
- Translate
- Translate 3D
- Turn Profile

The interface for these functions has the same look and feel as the Solids interface, allowing you to work in the function panel and in the graphics window simultaneously.

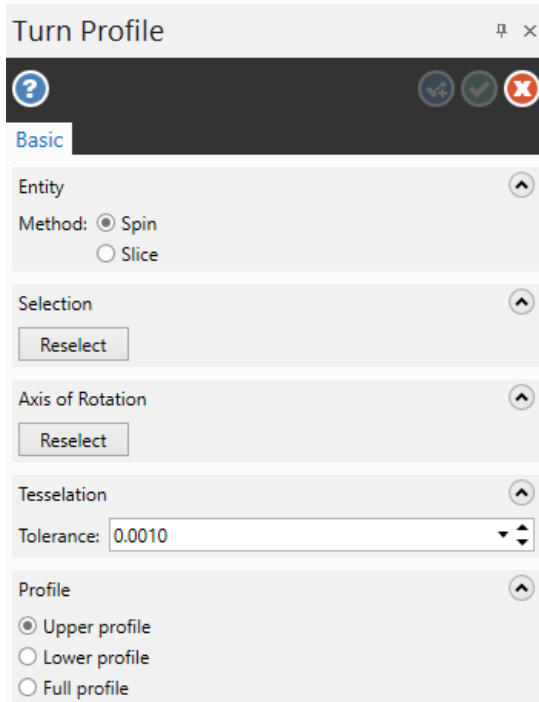

Work Offsets

When you update a plane's work offset, the Update Plane dialog box now indicates how many operations are affected by the change. After selecting an update option, the right side of the dialog box shows which planes will be updated.

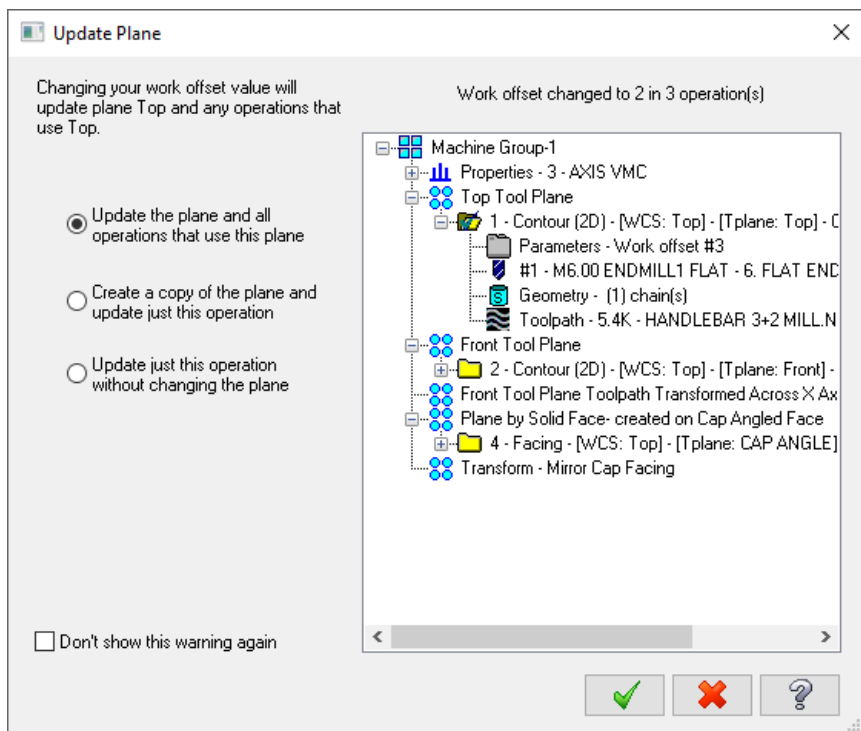

You can select different update options and see which operations will be affected before committing the change.

XML Post Text

The Control Definition Manager's Text page right-click menu has been enhanced. You can now change the text item to display as **User text**, **System column text**, or as an **XML item tag**.

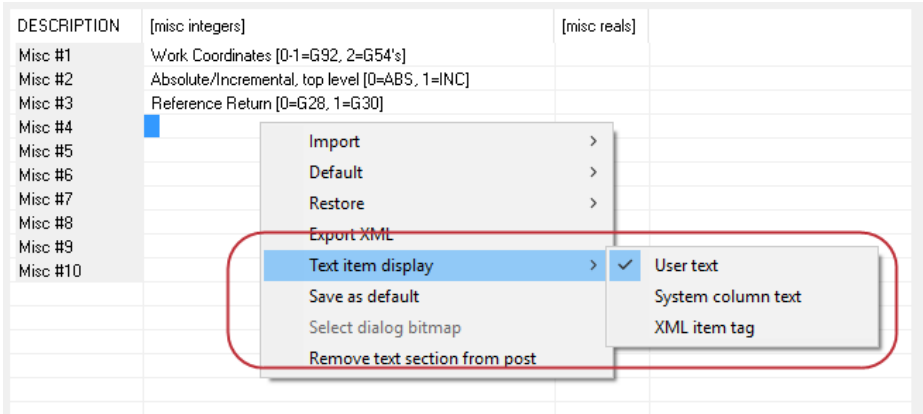

Export Text and **Export XML** have been changed to only export as XML. You can no longer output as text.

When importing into the Control Definition Manager, the Post Text dialog box has been enhanced to now display the **Control key** and the **Language key**.

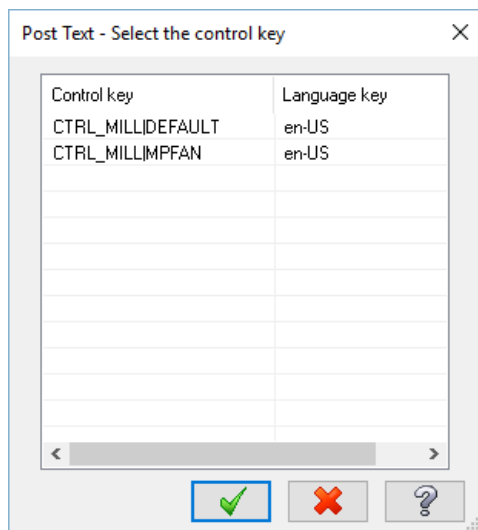

You can also use the Post Text dialog box to remove control keys, by selecting **Remove text section from post** from the right-click menu.

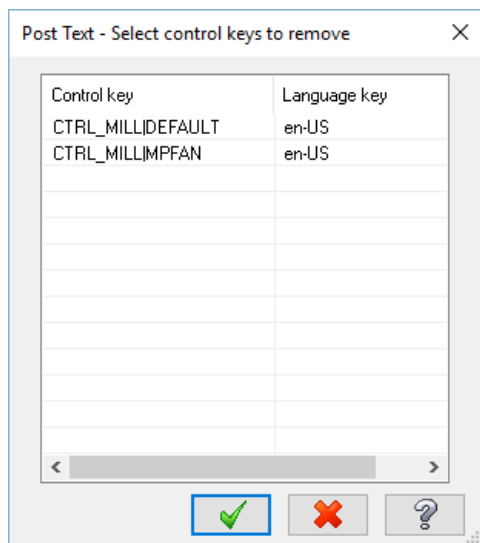

DESIGN ENHANCEMENTS

Listed below are design enhancements made to Mastercam 2018. These include improvements to Solid, Model Prep, and Wireframe functions.

Angle Sweep

To improve the creation of more complex wireframe functions and when creating or editing primitives, there are now on-screen sweep and rotate controls.

These controls can snap to the AutoCursor positions of existing entities, including tangencies. Additionally, the controls recognize horizontal and vertical snap positions based on the gnomon orientation.

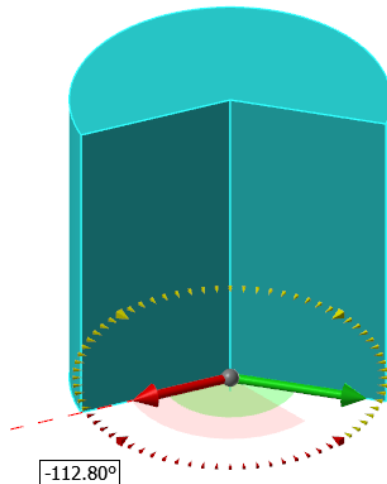

- All primitives with the exception of Block now include a sweep control.
- All wireframe functions, with the exception of Polar arcs and Ellipses, now include a sweep control.
- Rotate controls were added to the following wireframe functions: Polygon, Ellipse, and Rectangular Shapes. This also applies to Roll, located on the **Transform** tab.
- Helix and Spiral now include a single-axis control that lets you graphically modify the height of the shape you are creating and editing.

Seam Control

To make Roll and Unroll results easier to predict, a new gnomon based rotation control is now available. You can visually rotate the seam to see how geometry will respond, as well as snap to AutoCursor positions.

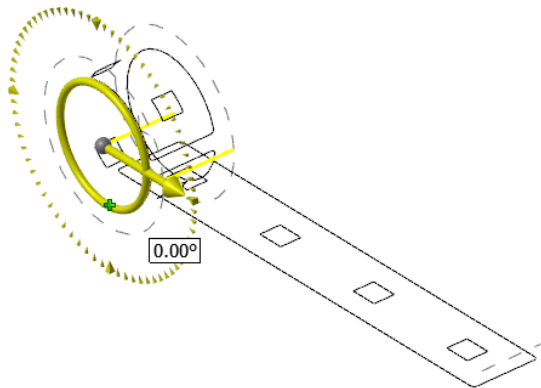

Drafting Enhancements

Listed below are enhancements made to Drafting functions.

Align Note

Previously available as a C-Hook, Align Note is now available on the **Drafting** tab. Align Note allows you to move existing notes and labels in such a way that they are more organized and easier to read.

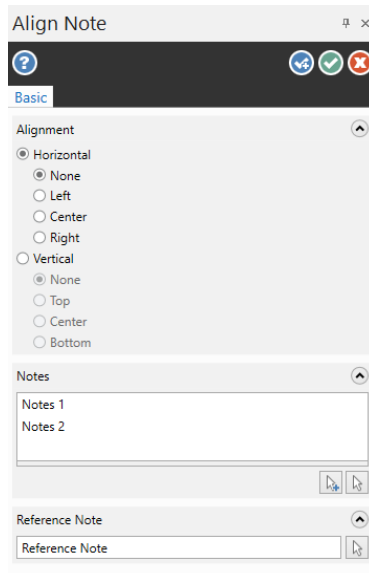

After selecting the function, select the notes you wish to align, and then choose a note to use as the reference position. You can then make any adjustments needed from the function panel.

Cross Hatch

The Cross Hatch function has been moved into a function panel, allowing you to make edits to the pattern, spacing, and angle before creating the cross hatch. Cross Hatch is also live, allowing you to see what you are creating before accepting it.

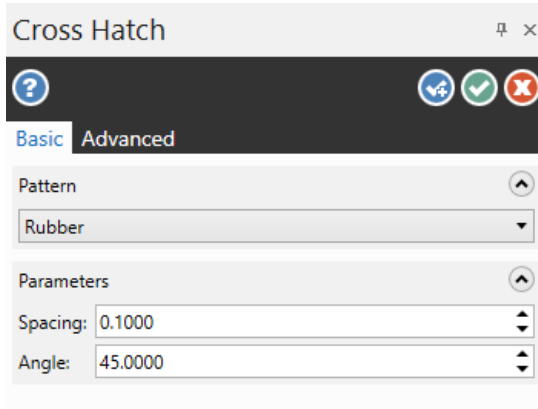

To access the Custom Hatch Patterns dialog box, select **Define** on the **Advanced** tab.

Leader

You can now create standalone leaders, which was previously only available in the Note dialog box. Unlike notes, labels, and letters, leaders are not live entities and cannot be edited.

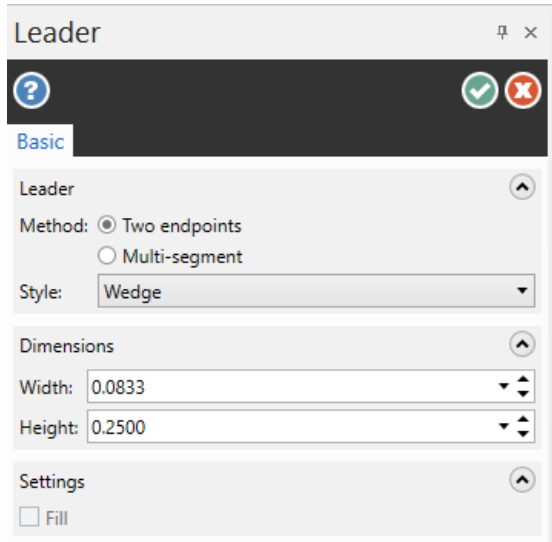

Smart Dimension

Enhancements made to Smart Dimension makes it easier to create multiple dimensions and then align the dimension orientation.

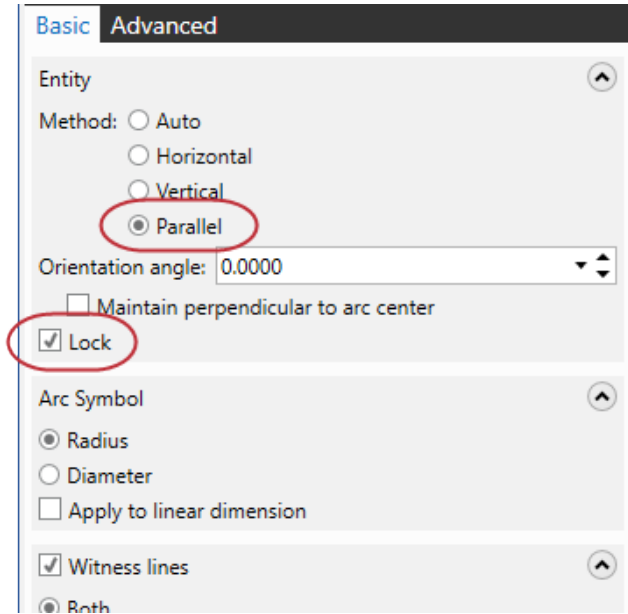

- The new **Parallel** option aligns the dimension orientation to be parallel to your selected geometry.
- Methods used to align dimension orientations (**Auto**, **Horizontal**, etc.) are now available anytime you are in the function, not just after creating and placing a dimension.
- When you select **Lock**, the specific **Method** you have selected stays active until you change it. You can easily create multiple dimensions using a specific orientation without having to reset it.

Model Prep Enhancements

Listed below are enhancements made to Model Prep functions.

Hole Axis

Hole Axis is now easier to use with a large number of holes, especially holes with matching diameters that are selected as a group.

When you hold down the [Ctrl] key to select all holes with the same diameter, Mastercam calculates the top based on the direction of the hole. The result can be undesirable with multiple holes pointing in different directions.

In previous releases, you had to individually select the axis inside the hole or select and then re-select each arrow to change the direction of the vector. In 2018, the vector arrow is larger and is selectable to make it easier to manage directions on a small set of holes.

Direction options

The new **Direction** options allows you to change the direction of the holes.

- Use **Defined** to point the holes in the direction determined by the Orientation option.
- Use **Opposite** to flip the holes opposite of the direction determined by the Orientation option.
- Select **Include blind holes** to flip the direction of theoretical blind holes, but not true blind holes. A true blind hole has a physical bottom inside of the solid. A theoretical blind hole passes completely through a section of the solid.

Orientation options

Use the new Orientation options to determine the direction of the top of the holes.

- Select **First pick** to use the direction of the first selected hole (as defined by the solid) and force all holes to use the same direction.
- Select **Cplane** to orient the top of the selected holes to match the positive direction of the Z axis of the current Cplane.

Multiple Undo/Redo

In previous versions, any changes made to solid models using the Model Prep functions could not be reverted. Now, you can undo and redo up to twenty-five Model Prep functions using the new **Undo** and **Redo**, located on the Solids Manager.

The Model Prep **Undo** and **Redo** are unrelated to Mastercam's Undo and Redo. They only affect changes made using the Model Prep functions. Applying a history-based Solid function to the model clears the Undo and Redo memory stream and makes any previous Model Prep changes permanent.

Solid Enhancements

Solid Sweep

Solid Sweep now has more options and controls than in previous releases. Solid Sweep operations from previous releases will still have limited features when edited in Mastercam 2018. Only newly created Solid Sweep operations will support the new options.

3D Along curve

Solid Sweep now supports 3D Along curves in addition to 2D Along curves.

End Profile Chain(s)

End Profile Chain(s) allows you to transition from one profile to another while traveling down the **Along Chain**.

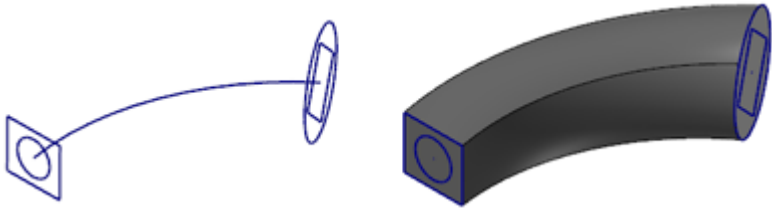

Each profile must have an equal number of entities, but the profiles do not need to be chained in sync. The chains must contain the same number of entities, even if the shape is different.

Guide Chain

Use a **Guide Chain** to influence a Solid Sweep operation by introducing a chain that alters the shape of the results. The images below depict the orange wireframe being swept across the blue wireframe. The green wireframe is the Guide Chain.

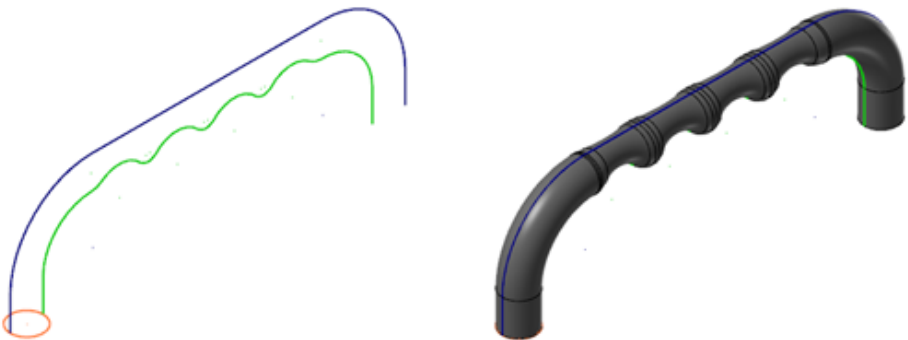

- **Guide Chains** that are offset by 180 degrees from the **Along Chain** yield the most predictable results.
- **Guide Chains** are not limited to the same plane as the **Along Chain**.

New alignment options

Two new options have been added to control the alignment between your profile and the Along chains. Previous releases always kept the same angle relationship between the Profile and Along curves. You can choose one of the following:

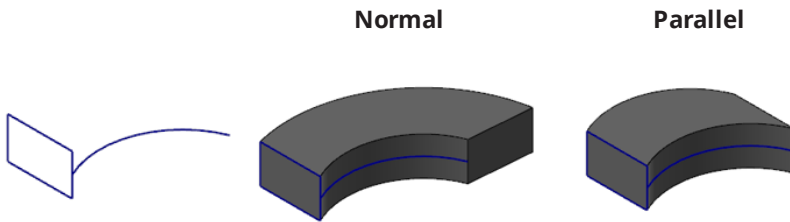

- **Normal** maintains the original angle relationship between the profile and along chain.
- **Parallel** keeps the cross sections parallel to the original profile.

The ability to control this relationship makes the exact placement of the profile in relation to the Along curve less critical.

Sharp corners

Prior to this release, Solid Sweep required a fillet between entities on the Along curve when there was a change in direction of more than 5 degrees. In Mastercam 2018, the profile geometry easily runs along sharp corners. If any sharp corners are encountered, Mastercam miter them.

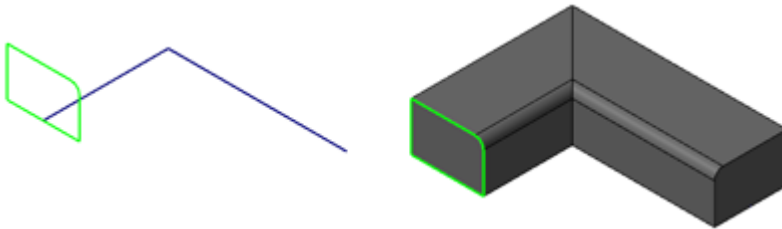

This enhancement gives you greater flexibility and precision when modeling.

Sweep Twist

Sweep Twist, under the **Advanced** tab, allows you to twist the profile as it travels the **Along Chain**. You can control the angle of the twist as well as its placement along the sweep. There is no limitation on the angle of the twist, and you can use the following options to apply the twist from a certain place:

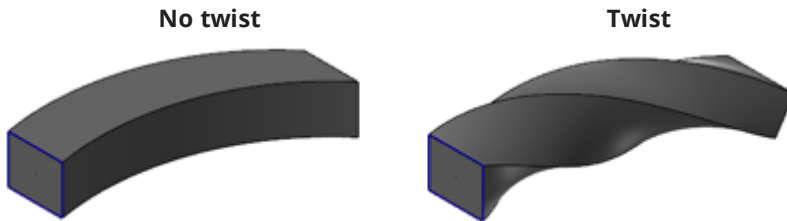

- The start of the **Along Chain** to the end
- The start of the **Profile Chain(s)** to the end of the **Along Chain**
- The start of the **Along Chain** to the **Profile Chain(s)**

Solids Manager

New icon

A new icon has been added to the Solids Manager that represents solid bodies with operations that have been rolled back and are dirty. This is especially helpful when there are many solid bodies and the bodies are collapsed so the history is not displayed.



Stop Operation placement

There is now a simpler way to manipulate the **Stop Operation** inside the history of a solid. You can now place the Stop Operation by selecting the operation you want to be last and selecting **Move Stop Op here** from the right-click menu.

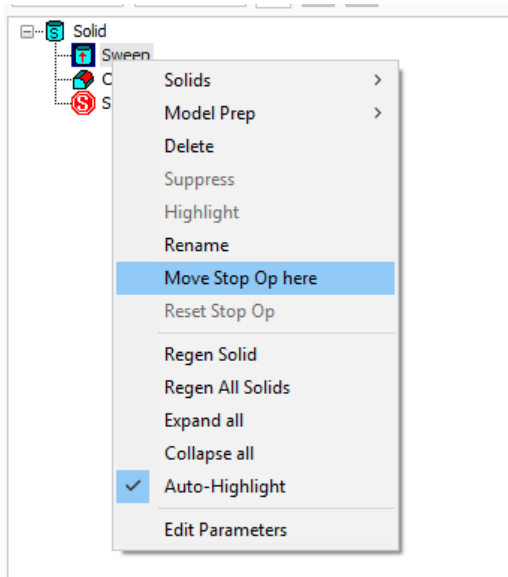

To reset the Stop Operation to the end of the history tree, right-click on the Solid tree and select **Reset Stop Op.**

Keep solid feature color

Mastercam now retains a solid's face and feature colors even after you have removed its history.

Solid face masking

You can now use the standard color masking tools found in the Quick Mask color selection to select solid faces when creating a surface from a solid.

Transform Enhancements

Listed below are enhancements made to the **Transform** functions.

Control start position

Rotate and Mirror now include a new option, **Translate**, which maintains the same start position of a closed circle when rotated or mirrored. If deselected, the start position of the circle moves as it did in previous Mastercam releases.

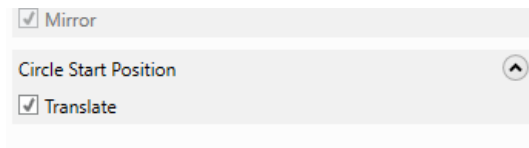

Scale conversion

You can now easily translate between inches to millimeters, or from millimeters to inches when using Scale. Select **Metric** or **English** in the Uniform group to scale your geometry.

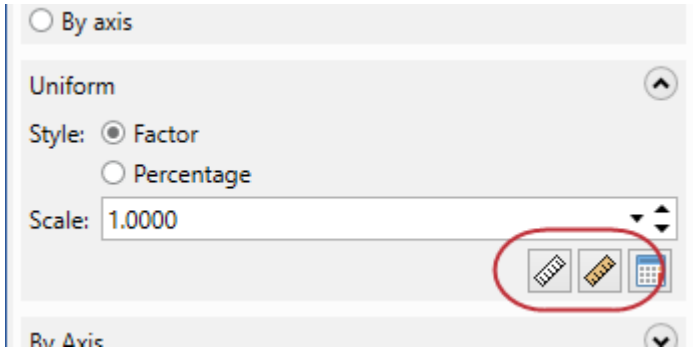

Wireframe Enhancements

Listed below are enhancements made to Wireframe functions.

Curve creation

The Curve functions, Curve One Edge and Curve All Edges, have been enhanced. These new features will help in the creation of more accurate containment boundaries.

Ignore adjoining solid edges

Select **Ignore shared edges** for Curve All Edges to identify any adjoining solid edges of the selected solid faces and ignore them when creating a curve.

Ignore shared edges off

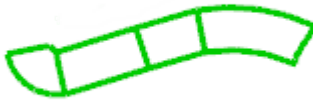

Ignored shared edges on



Only outside loops

Curve All Edges now allows you to create curves from only exterior edges of a solid and ignores the inner edges when you select **Only outside loops**. It is only active when solid faces are selected.

Select tangent edges

You can now [**Shift+click**] to select tangent edges in Curve One Edge.

Support for 2D and 3D modes

Curve One Edge and Curve All Edges now create geometry in both 2D and 3D mode. Previously, these functions only supported creating geometry in 3D mode. By supporting 2D geometry creation, geometry created from the selected edge can be projected to the current Cplane and Z depth, instead of requiring you to use another function, such as Project.

Create Letters

In previous versions, creating letters could require multiple attempts in order to get the results you wanted. Create Letters is now in a function panel, allowing you to work simultaneously within the graphics window.

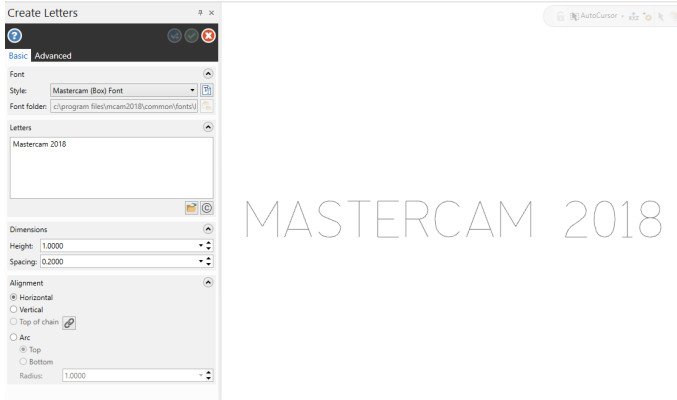

This also means that the letters are now live entities, so when you choose a new font, reposition, or edit the text it now shows the results in the graphics window.

Edit Spline

A new function has been added to the **Wireframe** tab, located under the **Refit Spline** drop-down. Use **Edit Spline** to refine and prepare splines. Edit Spline works on NURBS splines and converts any selected lines, arcs, or parametric splines into a NURBS.

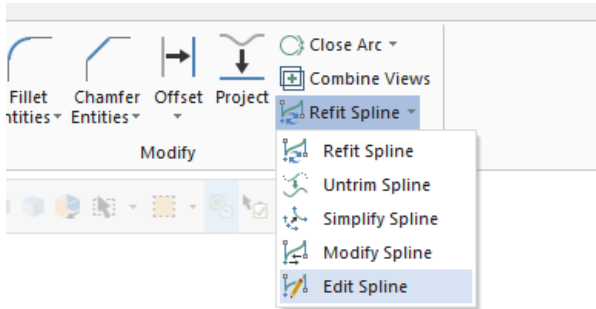

Edit Spline allows you to modify the tangencies and magnitudes of a curve at the spline's node points, or to edit tangencies at the vectors of control points. You can move, rotate, or lengthen the tangent vector or move the control point. For more control and a finer adjustment of the curve, you can add or remove node points, or increase the number of control points.

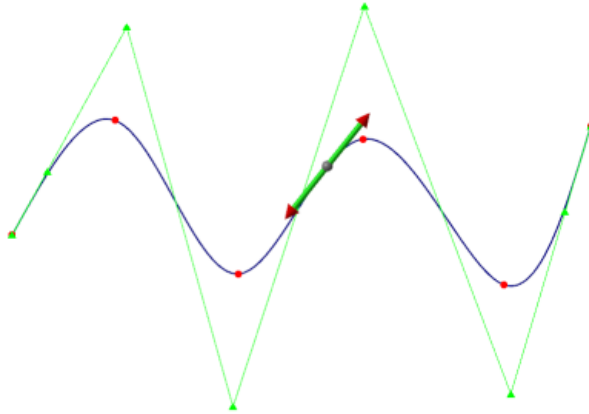

Helix and Spiral

Helix and Spiral function panels now include locks for specific fields. The fields you can lock are **Revolutions**, **Height**, **Pitch** for helix creation, and **Initial Vertical Pitch** for spiral creation. Locking allows you to specify one of the fields and then drive the others based on permutations of the equation:

$$(Pitch) \times (Revolutions) = Height$$

For example, when you are defining a helix, if you lock the **Height** at **10** and set the number of **Revolutions** to **5**, your resulting **Pitch** will be calculated as **2**. Locking a field does not prevent you from changing that value, it simply establishes which field is constant and which two are calculated.

Line Endpoint

Midpoint has been added to Line Endpoint. Select this option to create a line by selecting two points. The first point selected will be the midpoint and the second point will define one end while the other end of the line is a mirror in the opposite distance and angle.

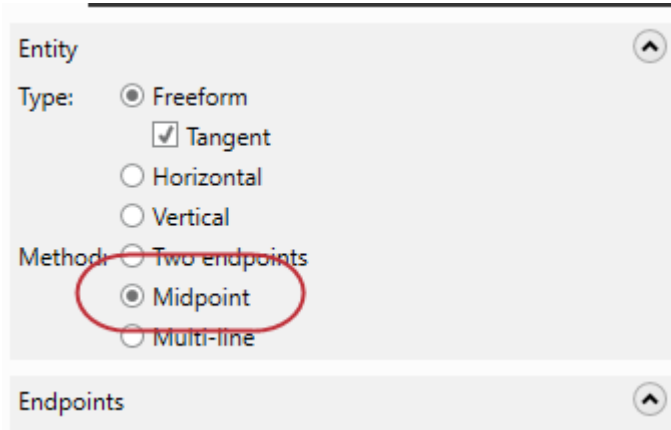

Modify at Intersection

A new function is now available on the **Wireframe** tab, located in the **Trim Break Extend** drop-down. **Modify at Intersection** allows you to trim, break, or create points with lines, arcs, and splines where they intersect with surfaces, solid bodies, solid faces, and solid sheet bodies. This is particularly useful when modeling or prepping for Multiaxis toolpaths.

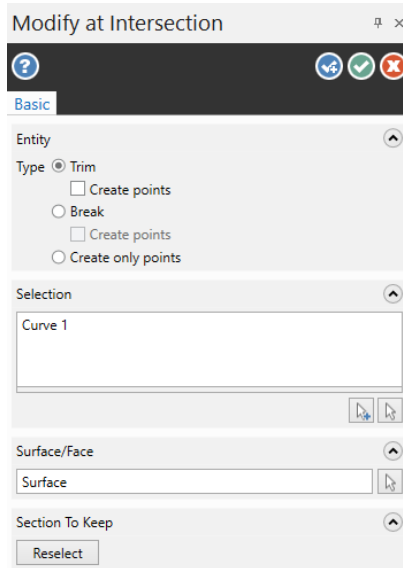

Select **Modify at Intersection**, and then use any selection method to select the wireframe geometry that you want to edit. After selecting the wireframe, select an intersecting surface, face, or solid body to display the function panel.

When trimming geometry, Mastercam keeps the wireframe on the Normal side of the surface or solid by default. To change this, click **Reselect**.

TOOL ENHANCEMENTS

Listed below are tooling enhancements made to Mastercam 2018 Mill tools.

Improved Inch and Metric Support

Mastercam now supports mixing inch and metric tools and holders when building tool assemblies in Mill. You can use metric tools in inch part files and inch tools in metric part files. This includes proper tool compensation and scaling in Backplot and Verify.

Note: This does not support scaling operation parameters when changing system units.

New Tool Importers

Support was added for importing tool assemblies from CoroPlus and Machining Cloud. Right-click in the tool list in the Mill Classic Tool Manager, and select **Import/export tools**, **Import tool data from**, and select the appropriate import option.

This launches another dialog box to allow you to select the tools you wish to import.

Importing with CoroPlus

When selecting **CoroPlus** from the right-click menu, the CoroPlus Tool Importer connects to the CoroPlus local host server and displays a list of all the tools that you have in CoroPlus' Assemblies list.

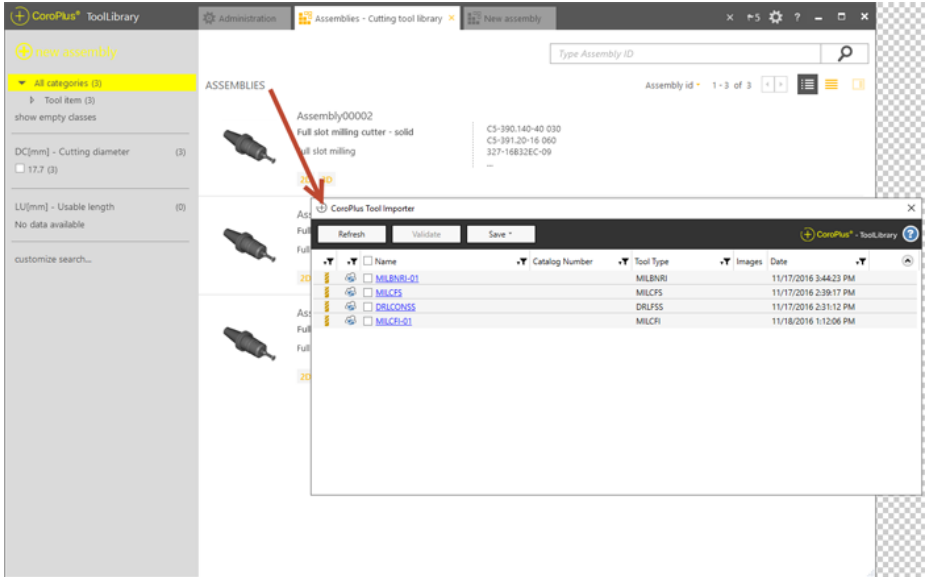

The cloud icon in the second column indicates that the associated tool assembly has not been validated.

To bring one or more tools into your Mastercam part or a `.tooldb` file, you select one or more items from the list, and select **Validate** at the top of the CoroPlus Tool Importer dialog box. If the tool assembly passes Mastercam's validation tests, you will see a green checkmark indicating that it can now be saved.

<input type="checkbox"/>	Name	Catalog Number	Tool Type	Images	Date
<input type="checkbox"/>	MILBNRI-01		MILBNRI		11/17/2016 3:44:23 PM
<input type="checkbox"/>	MILCF3		MILCF3		11/17/2016 2:39:17 PM
<input type="checkbox"/>	DRLCONSS		DRLFSS		11/17/2016 2:31:12 PM
<input checked="" type="checkbox"/>	MILCFI-01		MILCFI		11/18/2016 1:12:06 PM

If Mastercam detects problems with the tool, an icon will display indicating the severity of the problem. A red X indicates that there is a critical issue that must be resolved first. A yellow exclamation mark indicates a non-critical warning. Use the hyperlink in the description field to review or edit the tool in question.

Importing with Machining Cloud

When selecting Machining Cloud from the right-click menu, the Machining Cloud Tool Importer dialog box displays. The importer does not connect to a server process; instead, you import ZIP files containing your tool assemblies using the **Open** button.

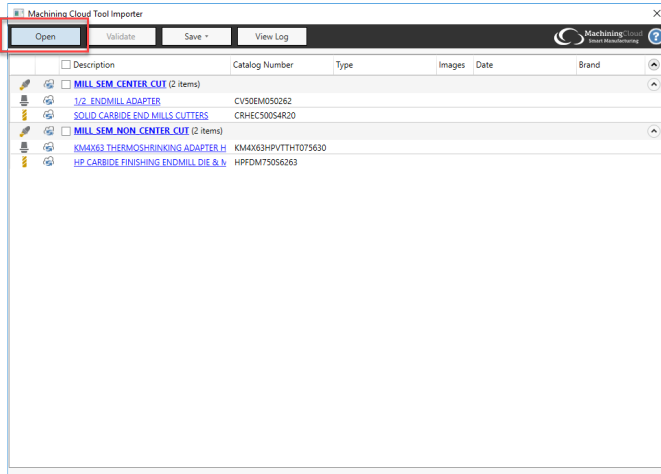

Similar to importing with CoroPlus (see ["Importing with CoroPlus" on page 80](#)), all assemblies must be validated before they can be used in Mastercam.

MILL ENHANCEMENTS

Listed below are Mill enhancements made to Mastercam 2018. This includes improvements to the 2D, 3D, and Multiaxis suite of toolpaths.

General Enhancements

Listed below are enhancements that apply to Mill toolpaths in general, not just 2D or 3D toolpaths.

Drill point sorting

Sort by name has been added to the Drill Point Manager right-click menu. This allows you to reset the sort order to the original selection order or in the order you have named the drill points.

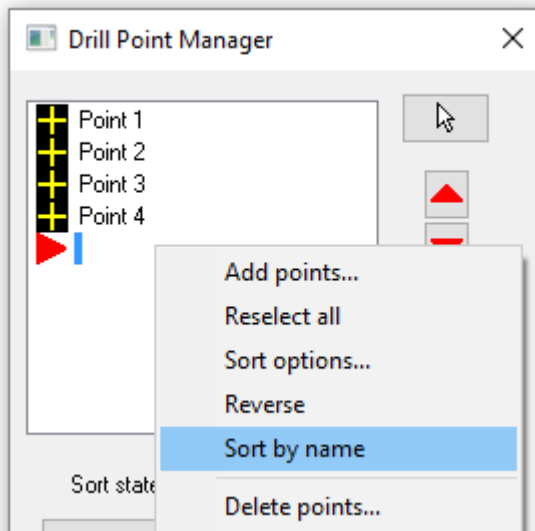

This is accessed through any toolpath that uses the Drill Point Manager, such as a 2D Hole making toolpath, Multiaxis Drill, or Multiaxis Circle Mill.

Override arc feed rate

You can now select to override the arc feed rate on the Arc Filter / Tolerance page of the following toolpaths:

- 2D Contour
- Slot Mill
- Waterline

As the tool moves through relatively small inside arcs, the perimeter of the tool is moving through the material faster than the center of the tool. When the cutter moves through outside arcs, the perimeter of the cutter is moving through the material slower than the center of the tool, which results in a decreased chipload on the tool.

By selecting **Override Arc Feed Rate** and entering a **Max ID decrease** or a **Max OD increase** value, Mastercam will adjust the feed rate for inside arcs and increase the feed rate for outside arcs by using the current motion's arc radius and the cutter size to calculate the proper feed rate.

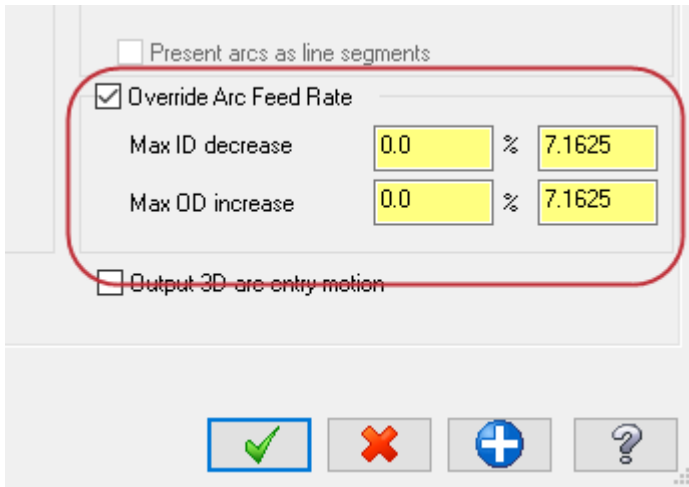

2D Enhancements

Listed below are enhancements made to the 2D suite of toolpaths.

Contour

The following enhancements apply to the standard 2D Contour toolpath.

Chamfer tool offset

In previous versions, you could only modify the **Tip offset** when chamfer milling, allowing you to control how far past the bottom chamfer rail the tip of the chamfer tool extends.

In 2018, Mastercam supports options to offset from the top or the bottom of your chamfer rail. **Top offset** places the full diameter of the chamfer tool at a specified distance above the top rail of the chamfer. **Bottom offset** amount ensures the tip of the tool clears the bottom of the chamfer. **Width** has also been renamed to **Chamfer width**.

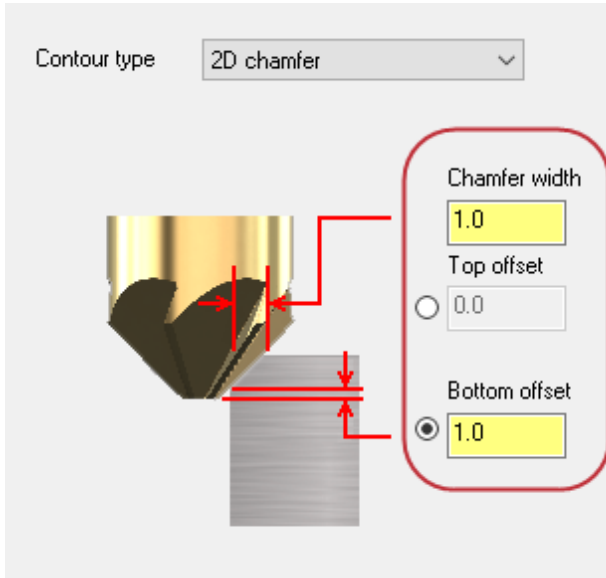

You can also now enter **0.0** for the **Chamfer width** when using a chamfer tool. This allows you to chain the top or bottom rail of an existing chamfer and place the chamfer where you desire using the top or bottom offset value.

Machine finish passes

Select **Machine finish passes after roughing all contours** on the Multi Passes page to machine finish passes after all rough cuts and depth cuts have been completed.

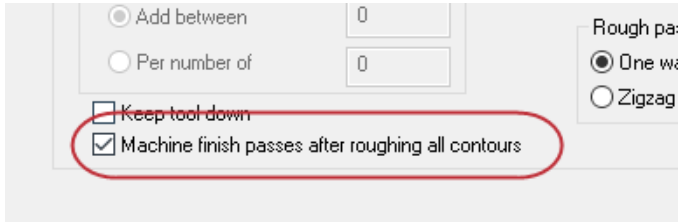

Multi pass order

In Mastercam 2017, multi passes were only ordered **By contour**, meaning it completed one chain before moving on to the next. In 2018, you can now choose **By contour** or **By pass** on the Multi Passes page.

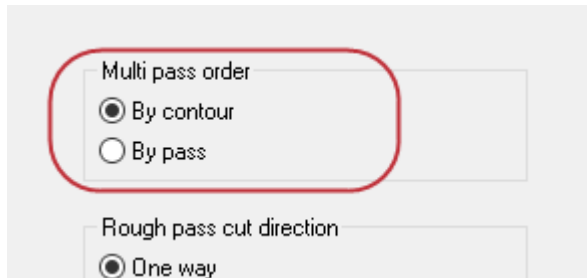

By pass orders the multi passes by pass number. It will run the first multi pass on all contours, then the second multi pass on all contours, and so on.

Rough pass cut direction

You can now control the cut direction of rough passes on the Multi Passes page. Select either **One way** or **Zigzag**. One way causes the rough multi

passes to behave as they did in past versions. Zigzag will alternate the cut direction between climb and conventional.

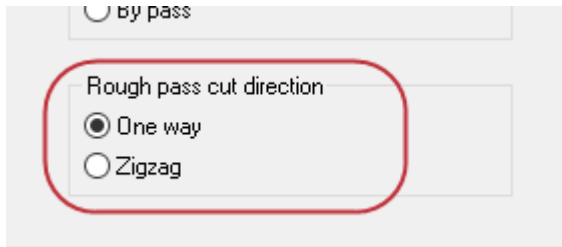

Both options respect the **Keep tool down** option.

Depth cut direction

Contour, Circle Mill, Pocket, and Facing toolpaths now support a **Step up** or **Step down** depth cut direction, located on the Depth Cuts page. These options allow you to order your cuts from top to bottom or from bottom to top.

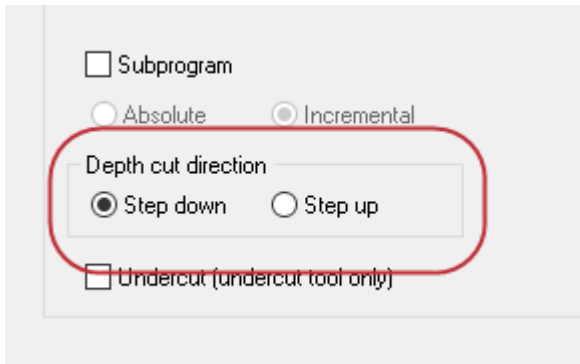

Depth cut order

Similar to Contour and 2D Pocket, you can now set the depth cut order **By region/By contour** or **By depth** on the Depth Cuts page for the following toolpaths:

- Dynamic Mill
- Area Mill
- Dynamic Contour

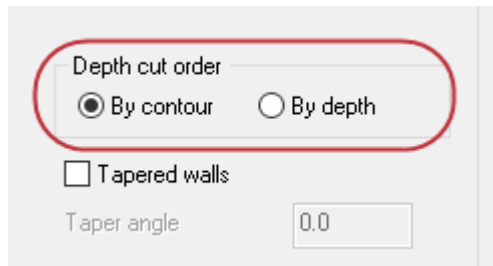

By depth machines at each Z level for all machining regions before stepping down. **By contour** and **By region** machine each machining region to completion before moving to the next.

Finish passes

Two options are now available on the Multi Passes page for Contour and the Finishing page for Circle Mill toolpaths. In previous versions, you could only machine finish passes at all depths or at the final depth. Now you can add or remove finish cuts, based on the number of rough depth cuts specified on the Depth Cuts page.

Add between creates a finish pass at all depth cuts and adds a specified amount of passes between depth cuts. For example, when set to **2**, Mastercam adds two evenly spaced passes between depth cuts. In the image

below, the red lines represent depth cuts and the blue lines represent multi-pass finish passes.



Per number of adds a finish pass only at every specified depth cut. A multi-pass finish pass is always added to the last depth cut. When set to 2, Mastercam adds a finish pass only at every second depth cut, depicted by the blue and red lines together below.

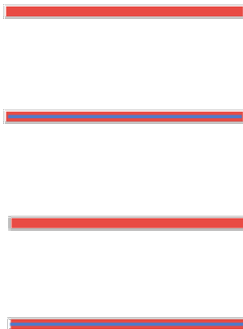

Linking associativity

You can use associative points to program your linking moves for most 2D toolpaths. These new features are located on the Linking Parameters page.

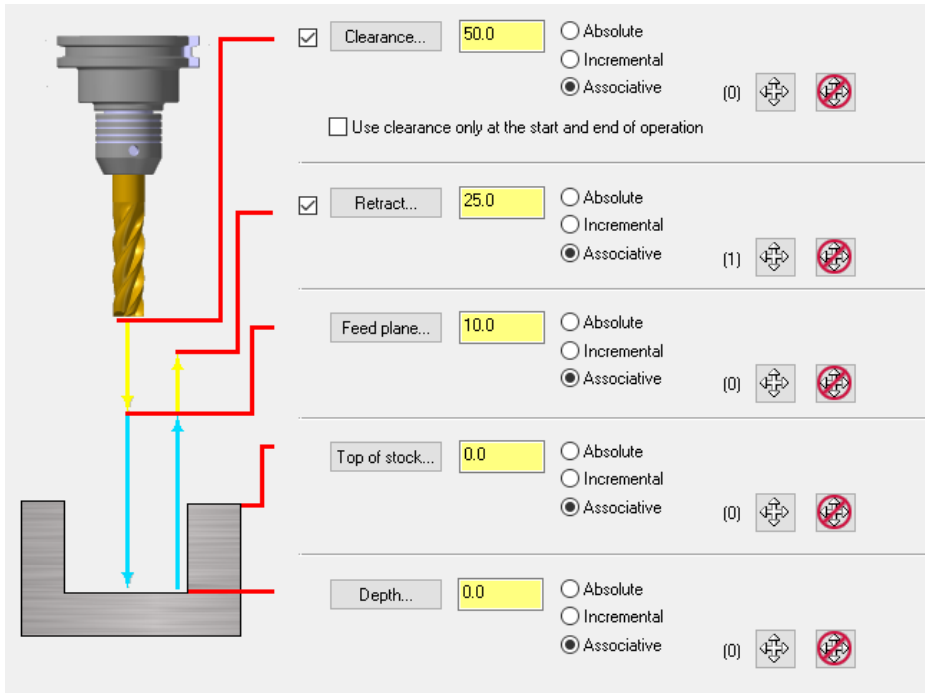

For example, if the top of a feature should be cleared by a certain amount, you can enter a **Clearance** amount, select **Associative**, and then pick a point on the feature in the graphics window. The Clearance plane will always be the specified incremental value above the point, even if the feature is moved.

The following toolpaths *do not* use the associative points:

- Point
- Engrave

- All Wireframe toolpaths

Plunge entry support

Plunge entry is now supported for Dynamic Mill toolpaths. Set the **Entry method** to **Plunge only** on the Entry Motion page. This option allows you to plunge directly into material. Previously, you had to set **Entry method** to **Helix** and the **Plunge angle** to **90°**.

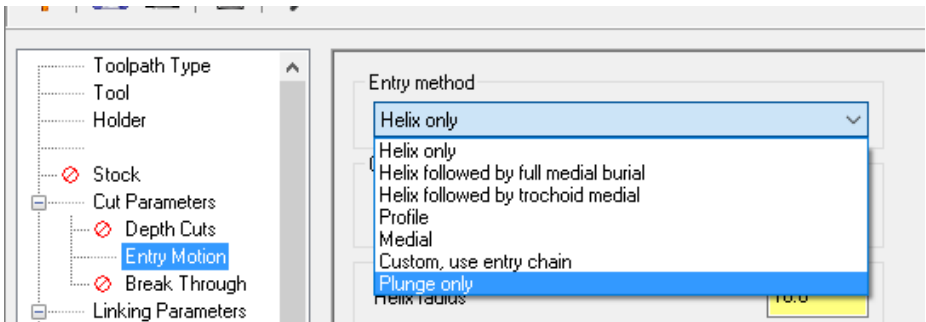

Spring passes

Spring passes has been added to the Finish Passes, Finishing, Multi Passes, or Rough/Finish page of the toolpaths listed below. **Spring passes** create additional finish passes along the same path as the last finish pass. In other words, use this option to create additional finish passes with a spacing of zero between the passes. This can be used for parts with thin material that may have flexed away from the tool during previous passes.

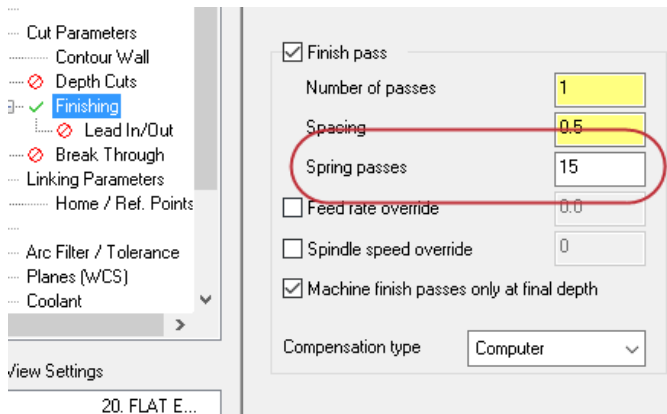

- Dynamic Contour
- Peel
- Blend
- Contour
- Slot Mill
- Circle Mill

Stock awareness

Stock awareness has been added to 2D Drill, Thread Mill, Helix Bore, and Circle Mill. The tool motion can now use the top, bottom, or both values of the stock. All of the linking parameters can be set to adapt to changing stock values.

Undercut support

Select **Undercut (undercut tool only)** when using an undercut tool to support tool compensation. This option is available on the Depth Cuts page for Contour, Pocket, Face, and Circle Mill toolpaths.

When a slot mill tool, with **Undercut (undercut tool only)** and **Step up** selected, there are the following changes:

- **Stock to leave** becomes inverted. It becomes a distance in $-/+ Z$ direction from the top of stock location.
- **Break through** becomes inverted. It becomes a distance in $-/+ Z$ direction from the top of stock location.

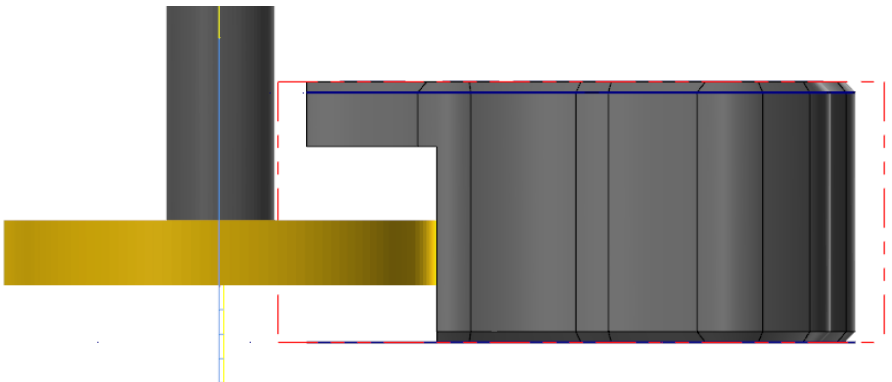

Taper support

Circle Mill toolpaths now support tapered walls. Select **Tapered walls** on the Depth Cuts page to angle depth cuts from the top of the stock to the final depth.

3D Enhancements

Listed below are enhancements made to the 3D suite of toolpaths.

Disable undercut tool support

When you select an undercut tool, but do not want to machine the undercut area, select **Detect undercuts** on the Rough Parameters tab for Surface Rough Pocket and on the Finish contour parameters tab for Surface Finish Contour. **Detect undercuts** disables undercutting when using an undercut tool.

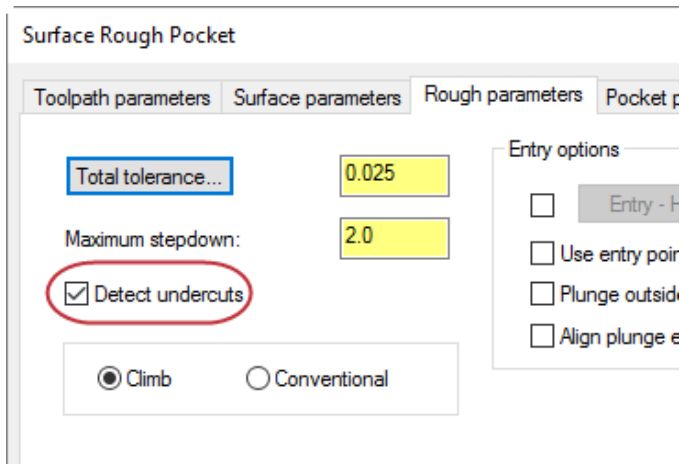

Follow containment

Follow containment has been added to the Steep/Shallow page for Water-line toolpaths. This option is only available when **Contact** is set to **Tool assembly contact**.

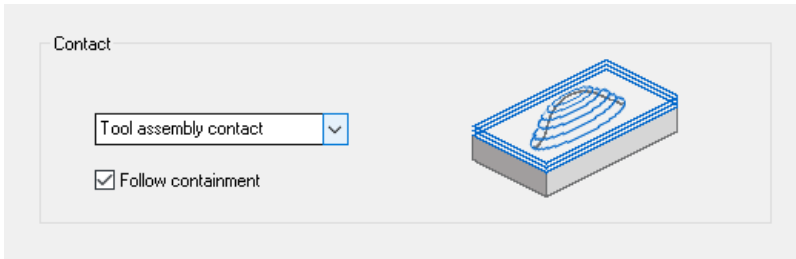

Follow containment allows the tool to follow the containment boundary back to the start of the cut, creating clean closed passes. This also helps to avoid partial cuts when a containment boundary was directly on top of a vertical surface.

High speed workflow

The workflow for all 3D High Speed toolpaths has been streamlined. You can now define which part geometry to machine and which geometry to avoid. For each geometry group you create, you can also assign variable stock to leave values on its walls and floors.

When selecting any of the 3D High Speed toolpaths, you are immediately brought to the Model Geometry page in the toolpath dialog box.

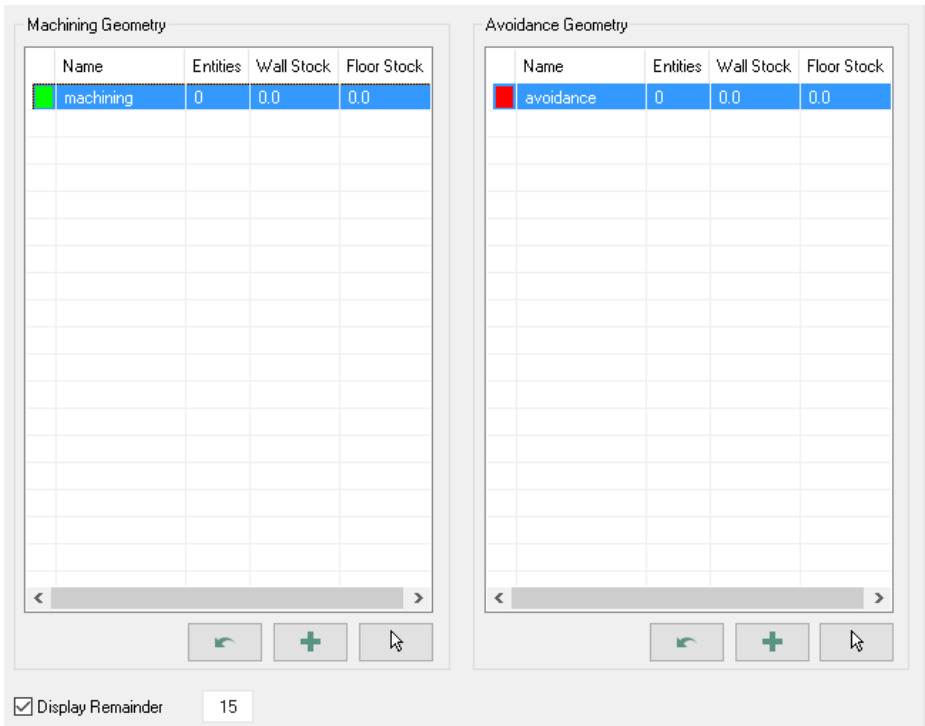

Use the Model Geometry page to create different types of geometry groups and define their attributes, such as color and the amount of stock to leave.

All of the geometry selection options that were previously located on the Toolpath Type page have been removed and relocated to the Model Geometry page or the Toolpath Control page.

The Toolpath Control page also includes options that were previously located on the Tool Containment page, which has been removed. On this page, you

can further refine your toolpath by setting an **Approximate start point**, the **Strategy**, and other options.

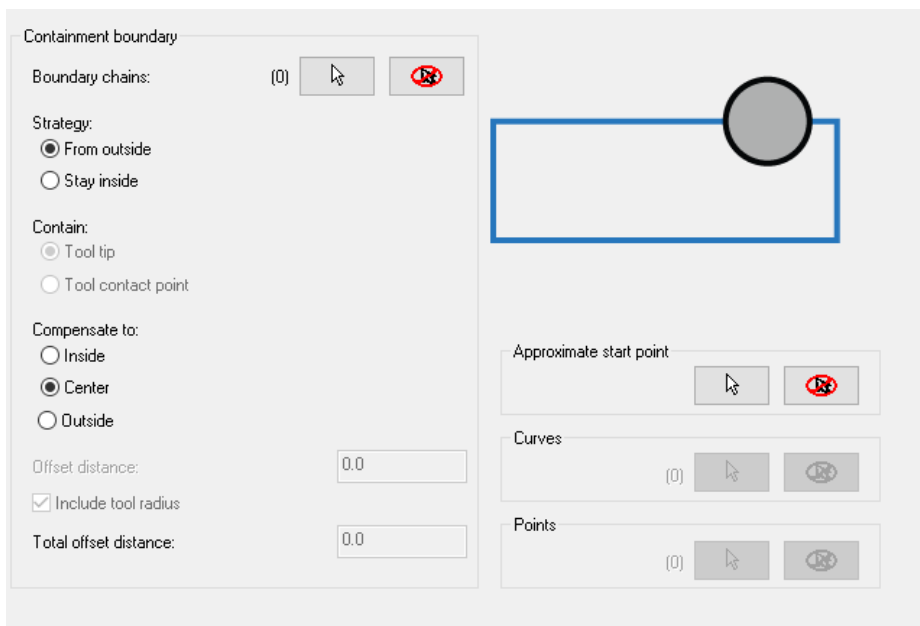

Smoothing

The high speed Hybrid toolpath now offers smoothing controls, similar to the **Sharp corner smoothing** options for the Finish Scallop toolpath. Select **Smoothing** on the Cut Parameters page to enable these options.



Angle is the minimum angle between two toolpath segments that you want Mastercam to consider as a sharp angle. **Blend distance** is the distance Mastercam will back away from the sharp corners before and after.

Smoothing off



Smoothing on

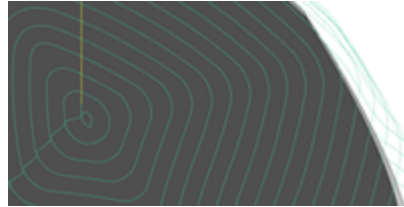

Multiaxis Enhancements

Listed below are enhancements made to the Multiaxis suite of toolpaths.

Collision Control page

The Collision Control page has been redesigned for 2018. The following list encompasses the changes made:

- Strategies 3 and 4 have been moved to a new Additional Collision Control Strategies page.
- Items on the Advanced Parameters page have been moved to the Collision Control page.
- The Tool Clearance page has been removed, and its parameters are now on the Collision Control page.
- **Shaft** has been renamed to **Shoulder**.
- **Arbor** has been renamed to **Shank**.

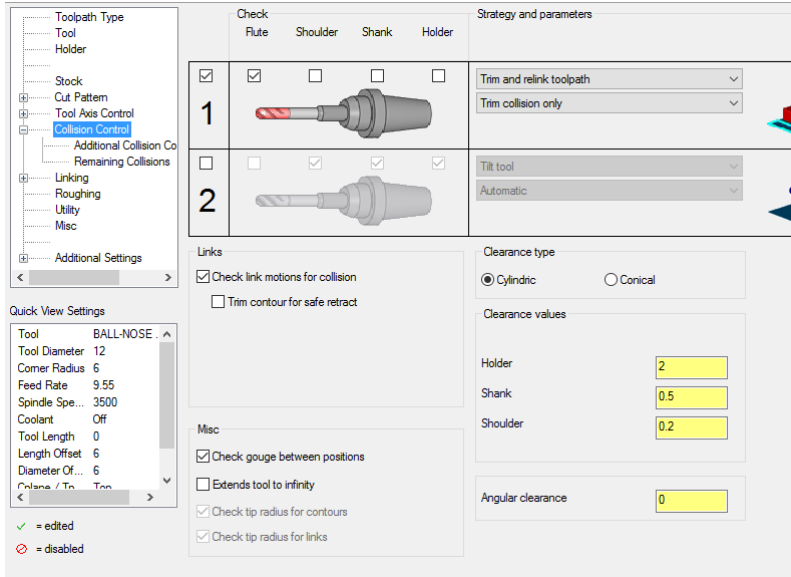

Common direction

Common direction has been added to the Tool Axis Control page, which keeps the tool at a uniform tilt angle to reduce tool and machine motion. It is available for the following toolpaths:

- Morph
- Parallel
- Along Curve
- Triangular Mesh
- Project Curve

Select **Common direction** and then choose either **On all contours** or **On single contour**.

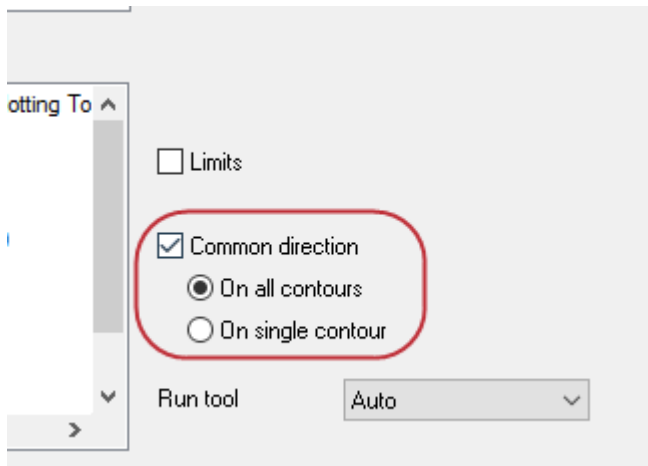

Dropping

Dropping has been added to the 3 to 5 axis toolpath. This option projects the 3 axis toolpath onto the selected surfaces, adjusting the tool vectors to be normal to the surface.

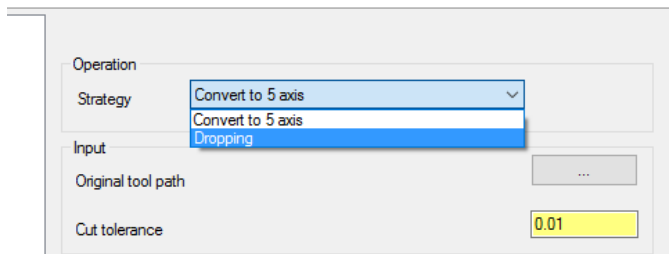

Line distance from curve

An option has been added to the Tool Axis Control page when using **Lines** for tool axis control for a Curve toolpath. This distance specifies how far from the curve a tool axis control line can be and still affect the tool.

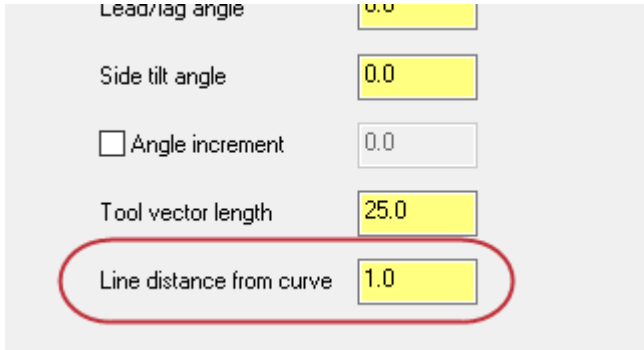

Maintain tilt

Maintain tilt keeps the tool tilted during retract and feed moves in an effort to reduce tool and machine motion. This option is available when **Tool axis control** is set to **Fixed angle to axis** on the Tool Axis Control page.

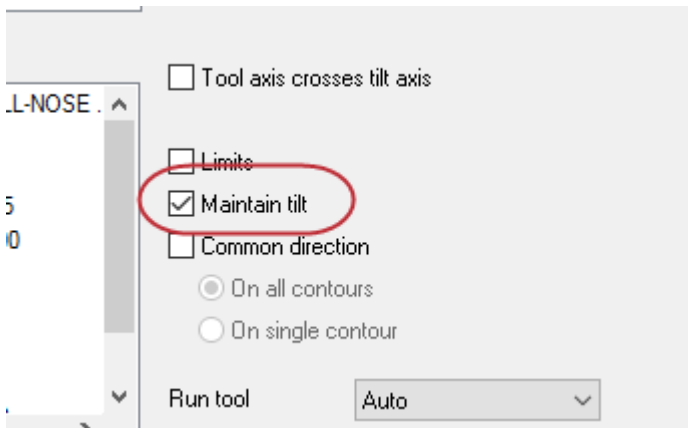

This option is available for the following Multiaxis toolpaths:

- Morph
- Parallel
- Along Curve
- Triangular Mesh
- Project Curve
- 3-to-5 axis

Multiaxis Link Safety Zone

The Multiaxis Link Safety Zone page has been redesigned. The images have been updated to better reflect the parameters, and a new **Define Shape** button has been added.

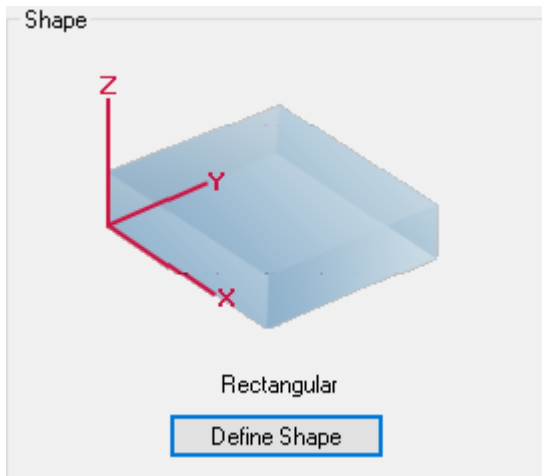

Select **Define Shape** to open the Safety Zone function panel, where you can alter and manipulate the safety zone to suit your needs.

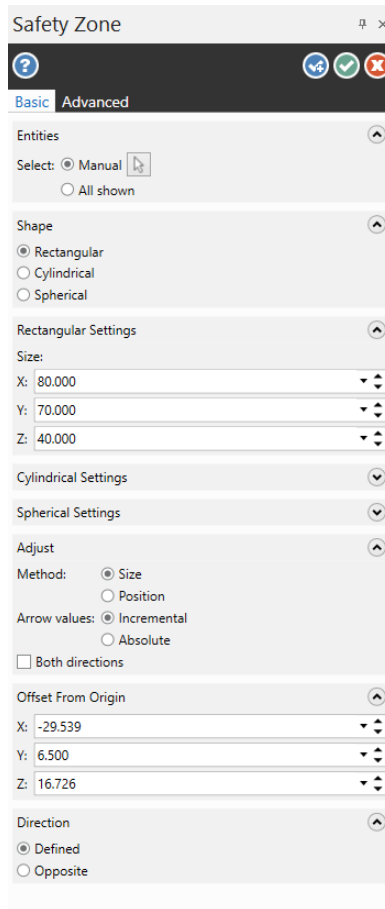

Surface edge tolerance

Surface edge tolerance has been improved, particularly when creating a Curve toolpath. If the curve lies on the edge of a trimmed surface or solid

face, and the surface or solid face is used as the normal to control the tool axis, the toolpath will generate as expected.

LATHE ENHANCEMENTS

Listed below are Lathe enhancements made to Mastercam 2018.

Chip Break

Chip Break, which was introduced in Mastercam 2017 for standard Rough and Contour Rough toolpaths, is now available for Face and Finish toolpaths. Use this option to establish when chip breaks occur.

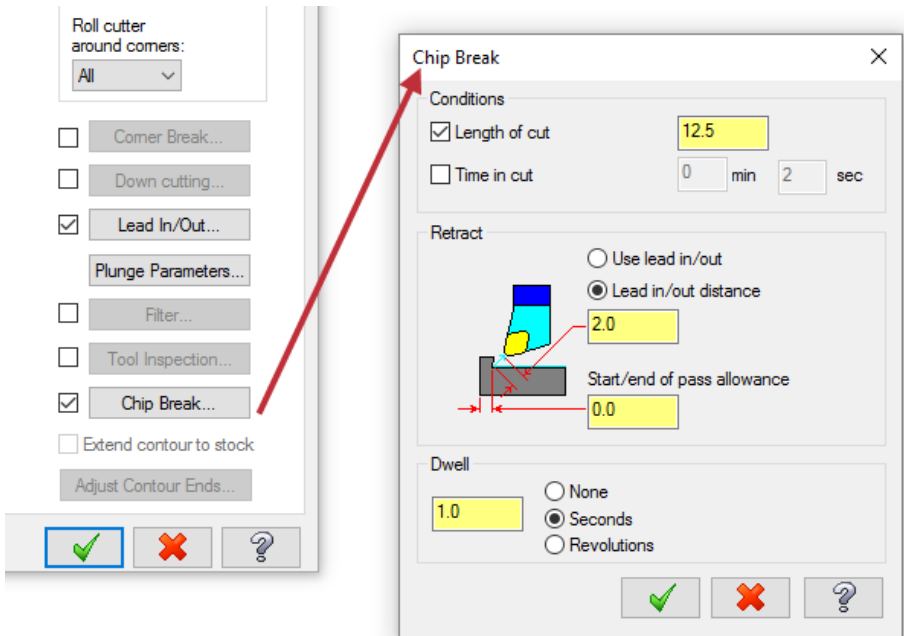

Chip Break is located on the Finish parameters and Face parameters tabs, respectively. Select the checkbox, and click **Chip Break** to open the dialog box. This option is valuable when working with stringy materials, such as aluminum or plastic, and allows you to set length and time conditions, retract, and dwell options.

Chip Break on

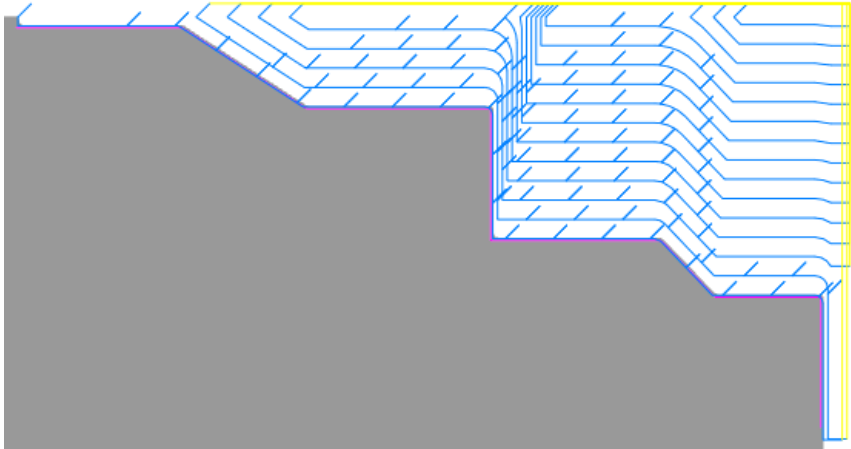

Chip Break off

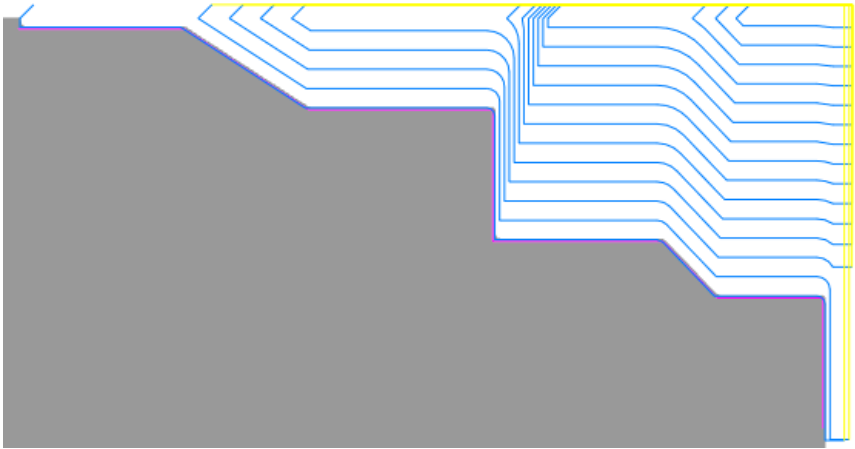

Groove Enhancements

Listed below are the enhancements made to the Groove toolpath.

Cut direction options

The **Bi-Directional** option on the Groove rough parameters tab has been changed to **Bi-Direction, Alternating**. With this option selected, after the toolpath's initial plunge, it alternates between negative and positive directions until the required material is removed.

The following options have also been added to the **Cut Direction** drop-down:

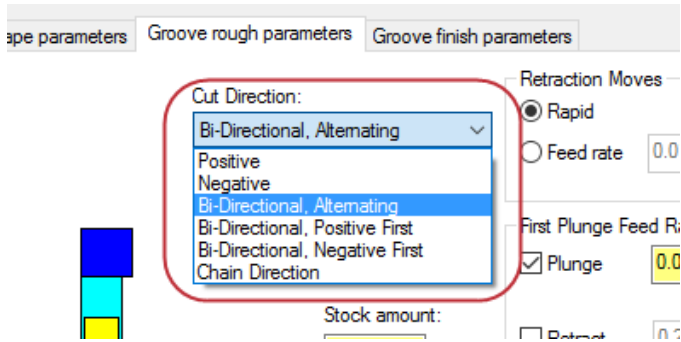

- **Bi-Directional, Positive First:** Machines the positive side first and then does the negative.
- **Bi-Directional, Negative First:** Machines the negative side first and then does the positive.
- **Chain Direction:** Machines in the direction of the chain.

Starting location

When cutting a face, Mastercam now calculates the optimal plunge point so that each side of the tool removes the same volume of material. This balances wear between the two sides of the tool. Shown below, the initial plunge point is offset so that the remaining stock has an equal volume on the X+ and X- side.

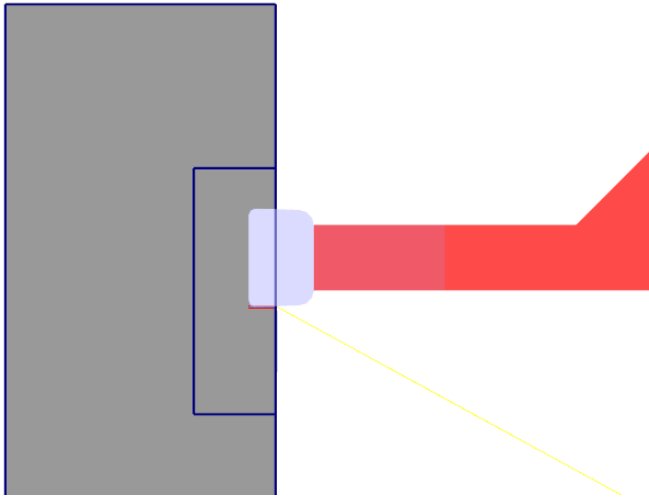

Prevent Up Cutting

Prevent up cutting defines the orientation of the non-cutting portion of the insert. This option is available on the Dynamic rough parameters tab for Dynamic Rough toolpaths.

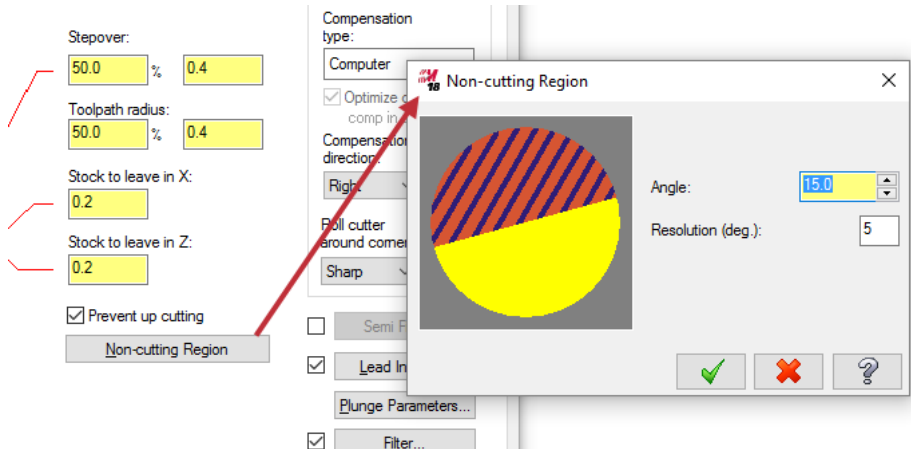

For example, in the image below, you can see the tool shank crashing into the material as it tries to cut the toolpath.

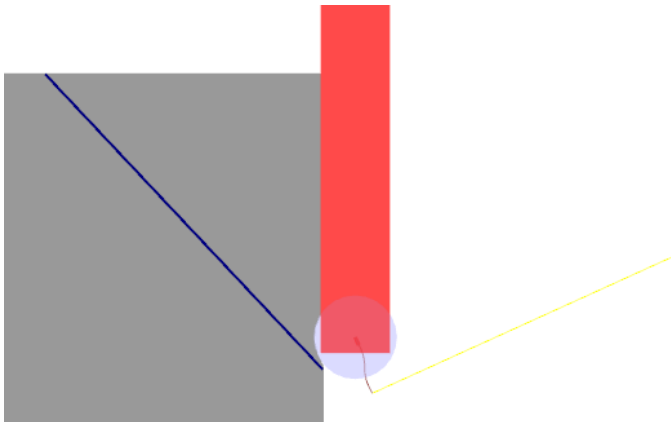

When **Prevent up cutting** is selected and **Angle** is set to **0** degrees, Mastercam generates a toolpath that cuts only with the lower portion of the tool insert.

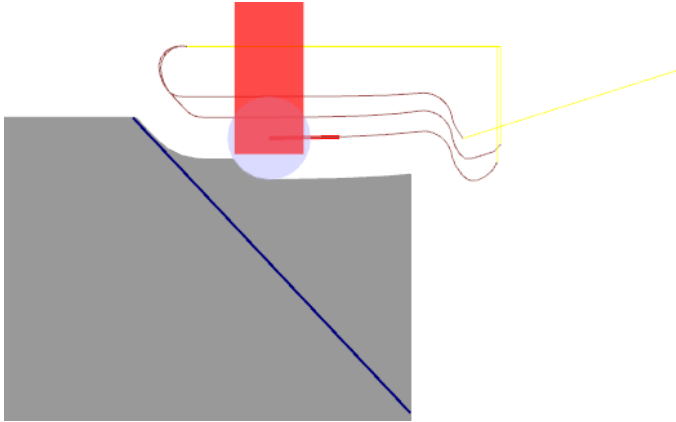

Rough Enhancements

Listed below are enhancements made to the standard Rough toolpath.

Section turning

Lathe Rough now has a **Section turning** option, located on the Rough parameters tab, that lets you cut stock in multiple sections. You can choose to break the toolpath into equal sections, into sections of exact distance with one section being the remainder, or equal sections based on the given distance.

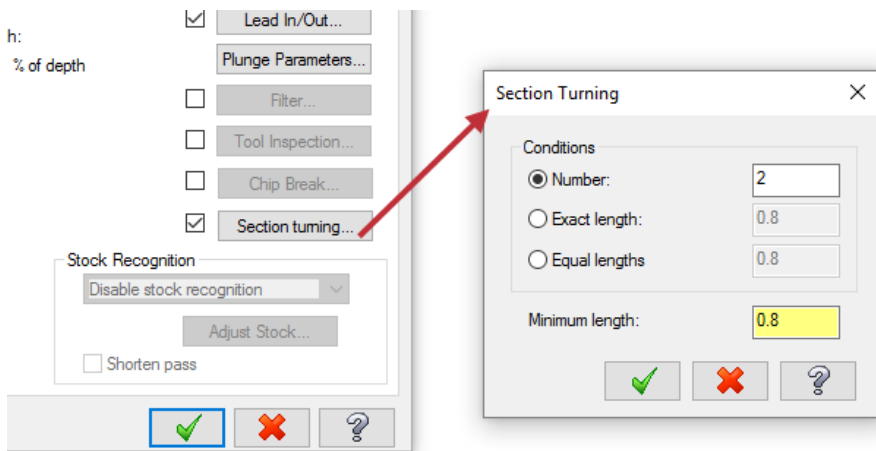

Section turning off

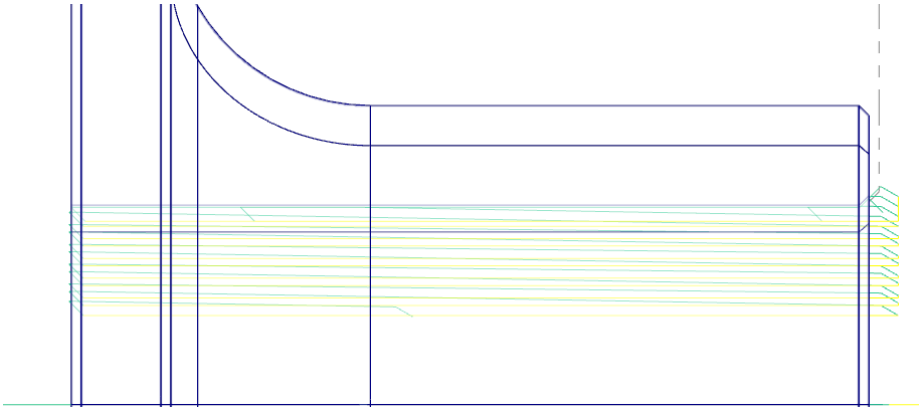

Section turning on (Set to Exact length)

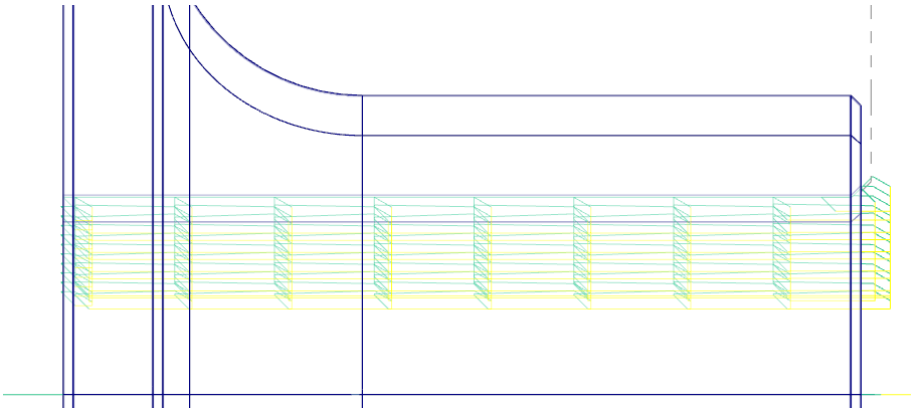

Semi-finish speed and feed

You can now set different feeds and/or speeds for the semi-finish pass in the Semi Finish Parameters dialog box for a standard Rough toolpath. To access this dialog box, select the checkbox, and select **Semi Finish** on the Rough parameters tab.

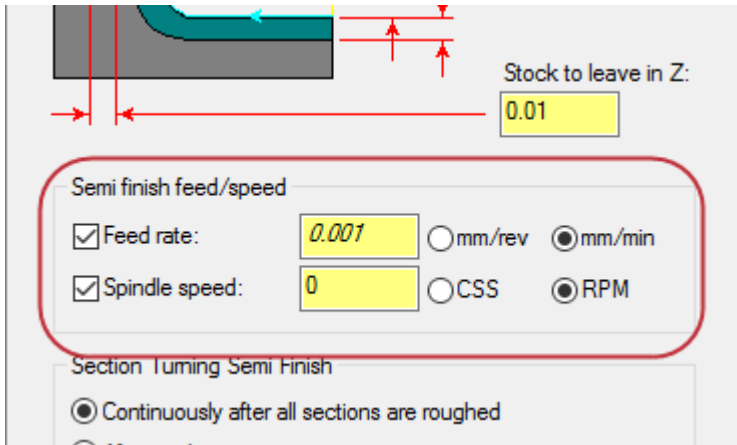

Stock Model Support

The Stock Model operation now supports Lathe and Mill-Turn part-handling operations. After the part handling operations complete, the stock model will end up with the stock boundary.

Tool Inspection

You can now perform a tool inspection at the end of a standard Rough toolpath. Additionally, **Tool Inspection** has been added to the Face toolpath on the **Face parameters** tab.

MILL-TURN ENHANCEMENTS

Listed below are Mill-Turn enhancements made to Mastercam 2018. This includes improvements to Job Setup, tool locators, and new toolpaths.

Center Support

Mastercam now supports center tool definitions, and you can now create a Center Point and Tailstock operation.

Right-click in a tool list and select **Create center** to create a center tool using the Tool Wizard, by defining the parameters manually or by importing custom geometry from a file.

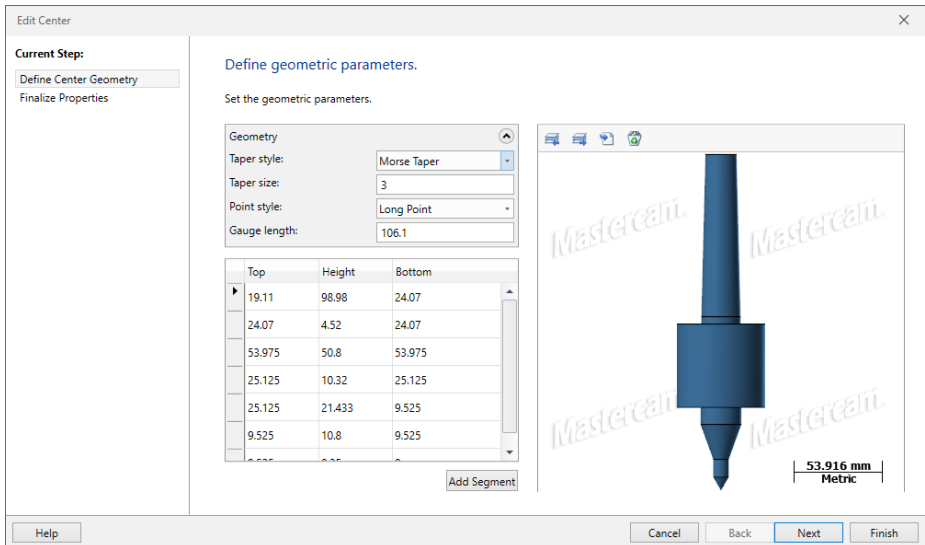

New Center Point toolpath

With the support for center tools, you can now create a Center Point toolpath. This new toolpath is located on the **Mill-Turn Turning** contextual tab in the Part Handling gallery.

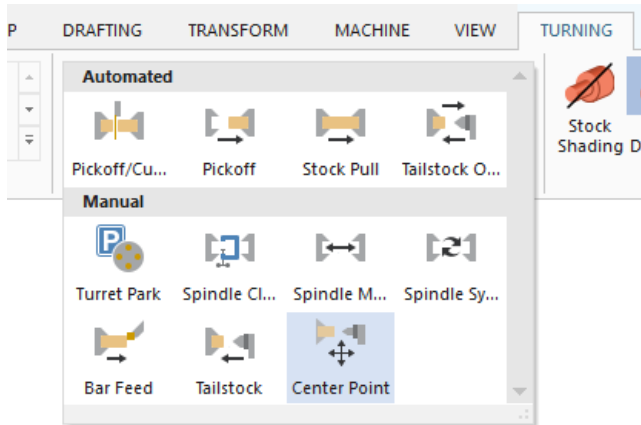

This toolpath is used when you need to mount a center tool in a turret and engage the tool for live center support.

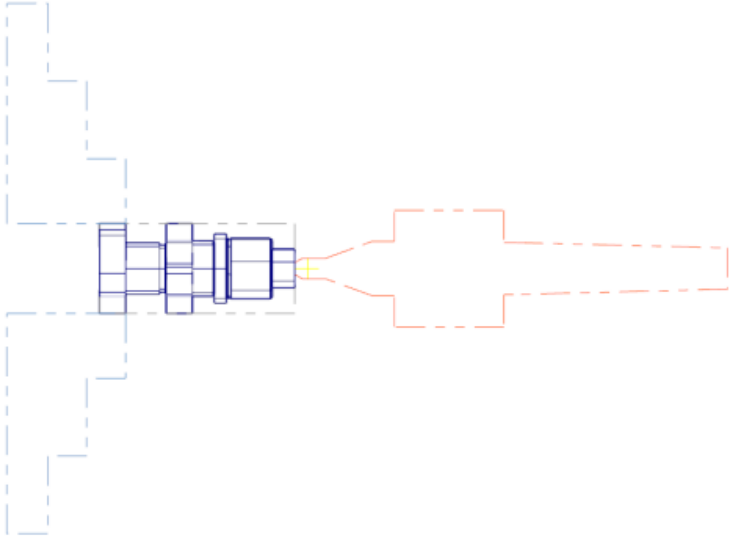

New Tailstock Operations

With the support for center tools, you can now create Tailstock Operations. This new toolpath is located on the **Mill-Turn Turning** contextual tab in the Part Handling gallery.

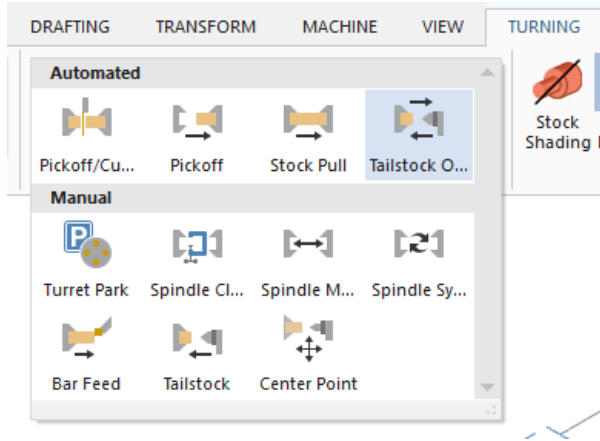

Use Tailstock Operations to quickly create a set of operations to load a center tool, move to stock clearance and, if applicable, advance the quill. The available tailstock options differ depending on the selected machine. For example, not all machines allow quill actions.

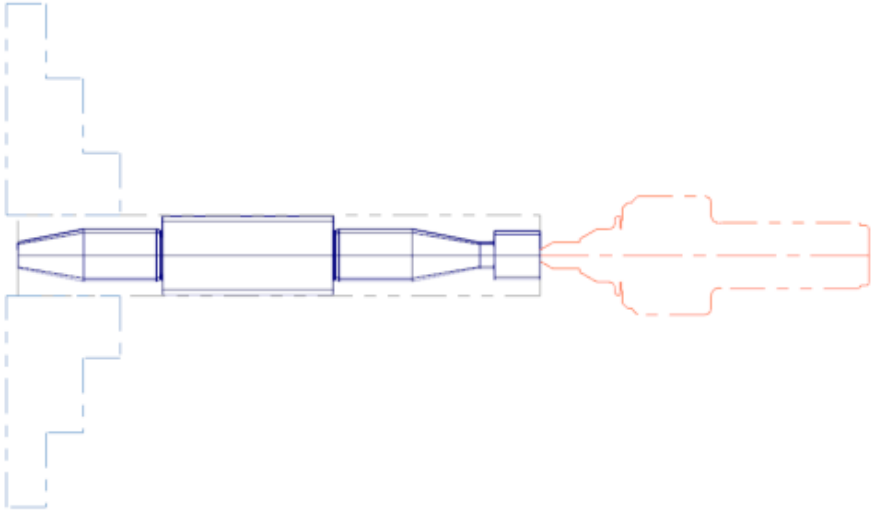

You can also create a set of tailstock operations to retract the quill and tailstock, and unload the center tool.

General Enhancements

- Edit common parameters is now available in Mill-Turn. Right-click on a toolpath in the Toolpaths Manager and select **Edit selected operations, Edit common parameters** to display the Edit Common Parameters dialog box.
- If you import an operation, Mastercam will check the Work Coordinate System (WCS) of the operations.

- You can now chain geometry on multiple planes, similar to Lathe chaining. All features can be toolpathed on multiple sides in one operation.

Job Setup Enhancements

Listed below are enhancements made to Job Setup.

Enable destination spindle

Select **Enable Right Spindle** or **Enable Left Spindle** when you want to use the second spindle for a stock pull. It is only available when the **Stock Type - Part Handling** is set to **No Pickoff** on the Setup Type page. The name of this option may vary depending on the **Stock Type - Part Handling** selected.

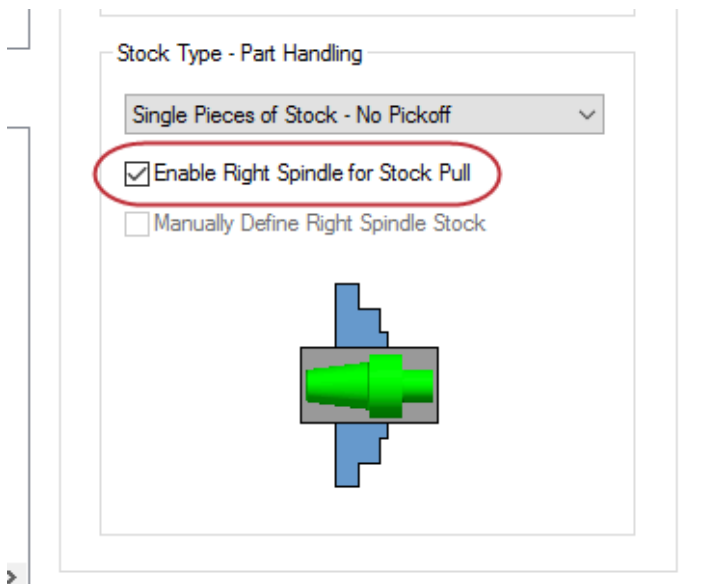

Manually define stock

Select **Manually Define Right Spindle Stock** on the Setup Type page to choose the stock for the second spindle, which is the stock that shows in simulation when it is launched. This entity can be derived from a stock model that reflects the initial spindle's operation.

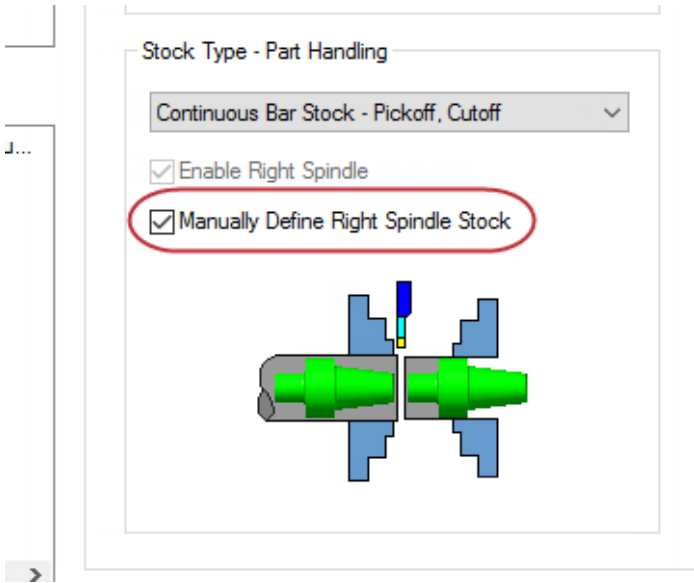

STL models

You can now use STL models to define stock.

Stock Type - Part Handling

You can now select **Two Separate Parts** in the **Stock Type - Part Handling** drop-down, in addition to **Continuous Bar Stock** and **Single Pieces of Stock**. This allows you to machine different parts on the left and right spindles.

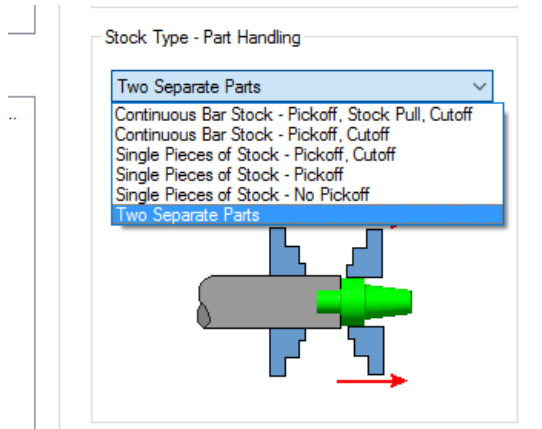

Tool Locators for B-axis Heads

Mastercam 2018 now includes support for tool locators for B-Axis heads. Spindle tool locators enable proper positioning of tools in the B-axis head. In Mastercam 2017, a tool in the B-axis head would generally have its compensation point along the centerline of the head.

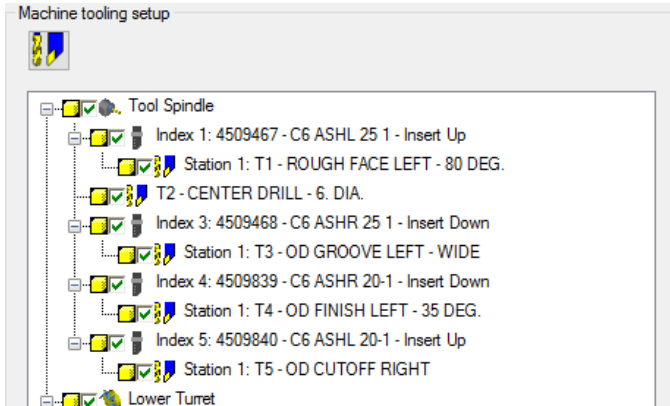

This support greatly improves collision detection and a clear representation of the how the tool is mounted in the machine.

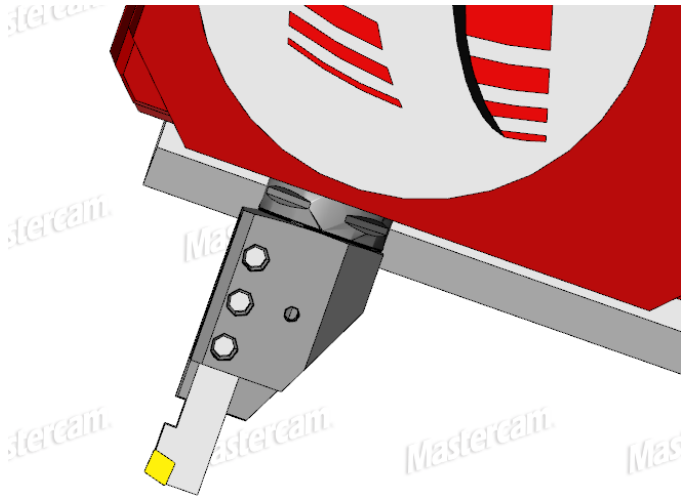

Additionally, multi-station tool locators are supported. This allows for realistic simulation of machine tool change motion. Instead of moving all the way to the tool change position, the spindle can move to any point you specify, index the locator, and quickly get back to cutting. These new locators are fully utilized in collision detection, including all tools mounted in the locators regardless of which tool is currently cutting.

The Tool Setup Manager also supports spindle tool locators.

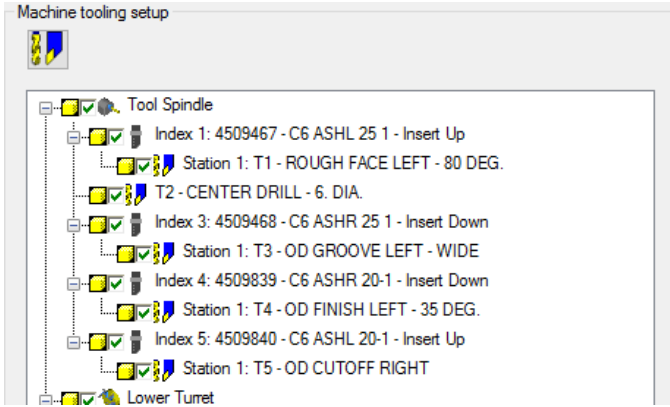



**ATTENTION! UPDATES MAY BE AVAILABLE.
PLEASE REFER TO Mastercam.com/support
FOR THE LATEST DOWNLOADS.**

CNC Software, Inc.

671 Old Post Road

Tolland, CT 06084 USA



www.mastercam.com

Mastercam[®]
Be Dynamic.

*Mastercam[®] is a registered trademark of CNC Software, Inc. © 1983-2016. All rights reserved.
All other trademarks are property of their respective owners.*